

Cat. No. W138-E1-03



# **SYSMAC C500-NC222-E**

## **Two-axis Position Control Unit (NC221 Mode)**

# **OPERATION MANUAL**

# **OMRON**

# C500-NC222-E

## Two-axis Position Control Unit (NC221 Mode)

Operation Manual

*Revised June 2003*

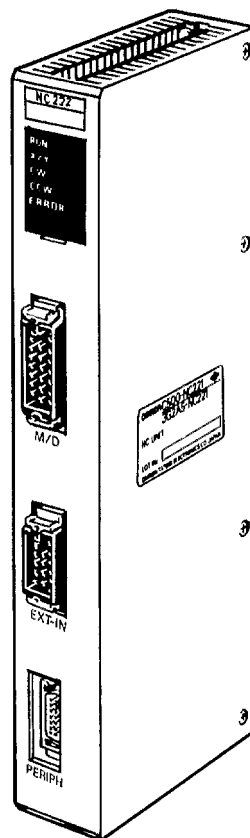





## **Notice:**

OMRON products are manufactured for use according to proper procedures by a qualified operator and only for the purposes described in this manual.

The following conventions are used to indicate and classify warnings in this manual. Always heed the information provided with them.

 **DANGER** Indicates information that, if not heeded, could result in loss of life or serious injury.

 **Caution** Indicates information that, if not heeded, could result in minor injury or damage to the product.

## **OMRON Product References**

All OMRON products are capitalized in this manual. The word “Unit” is also capitalized when it refers to an OMRON product, regardless of whether or not it appears in the proper name of the product.

The abbreviation “Ch,” which appears in some displays and on some OMRON products, means “word” and is abbreviated “Wd” in documentation.

## **Visual Aids**

The following headings appear in the left column of the manual to help you locate different types of information.

**Note** Indicates information of particular interest for efficient and convenient operation of the product.

**1, 2, 3...** Indicates lists of one sort or another, such as procedures, precautions, etc.

## **© OMRON, 1990**

All rights reserved. No part of this publication may be reproduced, stored in a retrieval system, or transmitted, in any form, or by any means, mechanical, electronic, photocopying, recording, or otherwise, without the prior written permission of OMRON.

No patent liability is assumed with respect to the use of the information contained herein. Moreover, because OMRON is constantly striving to improve its high-quality products, the information contained in this manual is subject to change without notice. Every precaution has been taken in the preparation of this manual. Nevertheless, OMRON assumes no responsibility for errors or omissions. Neither is any liability assumed for damages resulting from the use of the information contained in this publication.



# TABLE OF CONTENTS

<b>PRECAUTIONS</b> .....	<b>xi</b>
1 Intended Audience .....	xii
2 General Precautions .....	xii
3 Safety Precautions .....	xii
4 Operating Environment Precautions .....	xii
5 Application Precautions .....	xiii
<b>SECTION 1</b>	
<b>Introduction</b> .....	<b>1</b>
1-1 Features .....	2
1-2 Basic Operating Principles .....	2
1-3 Operational Flow .....	4
1-4 System Configuration .....	5
1-5 Control System Configuration .....	6
1-6 Control System Principles .....	6
1-7 Precautions When Using C500-NC222-E in NC221 Mode .....	10
<b>SECTION 2</b>	
<b>Wiring</b> .....	<b>17</b>
2-1 M/D Connector .....	18
2-2 EXT-IN Connector .....	21
2-3 Faulty Wiring Diagnostic Function .....	22
2-4 Motor Driver Connection Examples .....	24
2-5 Wiring Precautions .....	26
<b>SECTION 3</b>	
<b>Data Configuration</b> .....	<b>27</b>
3-1 Overview .....	28
3-2 Data Allocations .....	29
3-3 Setting Parameters .....	30
3-4 Setting Positioning Actions .....	42
3-5 Setting Dwell Times .....	48
3-6 Setting Acceleration and Deceleration Times .....	48
3-7 Setting Speeds .....	49
3-8 Initial Data .....	50
<b>SECTION 4</b>	
<b>Data Communication with PC</b> .....	<b>57</b>
4-1 Compatible Models and Words .....	58
4-2 PC Programs .....	59
<b>SECTION 5</b>	
<b>Operating Status</b> .....	<b>65</b>
5-1 Flag Transitions and Types .....	66
5-2 Status Word Allocations .....	68
5-3 Status Word Details .....	70
5-4 Flag Changes .....	77

# TABLE OF CONTENTS

<b>SECTION 6</b>	
<b>Commands</b> .....	<b>81</b>
6-1 Command Format .....	82
6-2 Command Descriptions .....	84
6-3 Command Processing .....	89
6-4 Interpolation .....	90
6-5 Relation between SRT and Positioning Actions .....	95
<b>SECTION 7</b>	
<b>Establishing the Origin</b> .....	<b>97</b>
7-1 CCHG .....	98
7-2 Origin Search (XORG, YORG, IORG) .....	98
7-3 Origin Compensation .....	100
<b>SECTION 8</b>	
<b>Programming Examples</b> .....	<b>101</b>
8-1 Data Word Allocations .....	102
8-2 Data Transmission Program .....	105
8-3 Basic Program Examples .....	108
8-4 Application Program Examples .....	115
<b>SECTION 9</b>	
<b>External Display, Switches, and Indicators</b> .....	<b>129</b>
9-1 External Display .....	130
9-2 Display Descriptions .....	131
9-3 Switches and Indicators .....	133
<b>SECTION 10</b>	
<b>Error Processing</b> .....	<b>135</b>
10-1 Procedure .....	136
10-2 Basic Troubleshooting .....	136
10-3 System Errors .....	136
10-4 Command/Data Errors .....	136
10-5 Communications Errors .....	136
<b>Appendix</b>	
A. Position Control Unit Specifications .....	137
B. External Display Specifications .....	141
C. Error Code List .....	143
D. Position Action Data Coding Sheets .....	147
<b>Glossary</b> .....	<b>151</b>
<b>Index</b> .....	<b>155</b>
<b>Revision History</b> .....	<b>159</b>

## About this Manual:

The C500-NC222-E Position Control Unit in NC221 mode is a Special I/O Unit for SYSMAC C500, C1000H, and C2000H Programmable Controllers (PCs) that support WRIT (87) and READ (88). This Position Control Unit (PCU) in NC221 mode is designed to control positioning through voltage outputs to a motor driver according to PC programming and external control inputs.

This manual covers the specifications and procedures necessary for installation and operation. It also describes data layouts and examples for communication between the PLC and NC222 Module in NC221 mode. Before attempting to operate the Position Control Unit, be sure to thoroughly familiarize yourself with the information contained in this manual. During operation, refer also to your PC Operation Manual for programming and system details. If you wish to enter data manually via the Teaching Box, please use this manual for wiring and setup only. Refer to manual number W145 for data entry and operations.

**Section 1** contains information on the features of the Position Control Unit, system configuration, and an overview of control system principles.

**Section 2** contains wiring diagrams and other information necessary for installation and connection of the Position Control Unit.

**Section 3** provides the minimum information necessary to assemble and test a servomotor driver system using both axes.

**Sections 4, 5, and 6** provide information essential for operation, including data configuration, the setting of parameters and positioning actions, communication between the Position Control Unit and the PC, and the use of status flags.

**Section 7** provides a description of command format. It also contains tables of system, servo control, and data processing commands, including the functions and usage examples for each.

**Section 8** shows how to establish the origin, which must be done to establish a reference point before executing positioning actions.

**Section 9** provides a variety of programming examples to illustrate the principles covered in this manual.

**Sections 10 and 11** cover external displays and error processing.

The appendices contain specifications, an error code list, and data coding sheets.

**WARNING**

Failure to read and understand the information provided in this manual may result in personal injury or death, damage to the product, or product failure. Please read each section in its entirety and be sure you understand the information provided in the section and related sections before attempting any of the procedures or operations given.



# PRECAUTIONS

This section provides general precautions for using the Programmable Controller (PC) and related devices.

**The information contained in this section is important for the safe and reliable application of the PC. You must read this section and understand the information contained before attempting to set up or operate a PC system.**

1 Intended Audience .....	xii
2 General Precautions .....	xii
3 Safety Precautions .....	xii
4 Operating Environment Precautions .....	xii
5 Application Precautions .....	xiii

## 1 Intended Audience

This manual is intended for the following personnel, who must also have knowledge of electrical systems (an electrical engineer or the equivalent).

- Personnel in charge of installing FA systems.
- Personnel in charge of designing FA systems.
- Personnel in charge of managing FA systems and facilities.

## 2 General Precautions

The user must operate the product according to the performance specifications described in the operation manuals.

Before using the product under conditions which are not described in the manual or applying the product to nuclear control systems, railroad systems, aviation systems, vehicles, combustion systems, medical equipment, amusement machines, safety equipment, and other systems, machines, and equipment that may have a serious influence on lives and property if used improperly, consult your OMRON representative.

Make sure that the ratings and performance characteristics of the product are sufficient for the systems, machines, and equipment, and be sure to provide the systems, machines, and equipment with double safety mechanisms.

This manual provides information for programming and operating OMRON PCs. Be sure to read this manual before attempting to use the software and keep this manual close at hand for reference during operation.

 **WARNING** It is extremely important that a PC and all PC Units be used for the specified purpose and under the specified conditions, especially in applications that can directly or indirectly affect human life. You must consult with your OMRON representative before applying a PC System to the abovementioned applications.

## 3 Safety Precautions

 **WARNING** Never attempt to disassemble any Units while power is being supplied. Doing so may result in serious electrical shock or electrocution.

 **WARNING** Never touch any of the terminals while power is being supplied. Doing so may result in serious electrical shock or electrocution.

## 4 Operating Environment Precautions

Do not operate the control system in the following places.

- Where the PC is exposed to direct sunlight.
- Where the ambient temperature is below 0°C or over 55°C.
- Where the PC may be affected by condensation due to radical temperature changes.
- Where the ambient humidity is below 10% or over 90%.
- Where there is any corrosive or inflammable gas.
- Where there is excessive dust, saline air, or metal powder.
- Where the PC is affected by vibration or shock.
- Where any water, oil, or chemical may splash on the PC.

-  **Caution** The operating environment of the PC System can have a large effect on the longevity and reliability of the system. Improper operating environments can lead to malfunction, failure, and other unforeseeable problems with the PC System. Be sure that the operating environment is within the specified conditions at installation and remains within the specified conditions during the life of the system.

## 5 Application Precautions

Observe the following precautions when using the PC.

-  **WARNING** Failure to abide by the following precautions could lead to serious or possibly fatal injury. Always heed these precautions.

- Always ground the system to 100  $\Omega$  or less when installing the system to protect against electrical shock.
- Always turn off the power supply to the PC before attempting any of the following. Performing any of the following with the power supply turned on may lead to electrical shock:
  - Mounting or removing any Units (e.g., I/O Units, CPU Unit, etc.) or memory cassettes.
  - Assembling any devices or racks.
  - Connecting or disconnecting any cables or wiring.

-  **Caution** Failure to abide by the following precautions could lead to faulty operation or the PC or the system or could damage the PC or PC Units. Always heed these precautions.

- Use the Units only with the power supplies and voltages specified in the operation manuals. Other power supplies and voltages may damage the Units.
- Take measures to stabilize the power supply to conform to the rated supply if it is not stable.
- Provide circuit breakers and other safety measures to provide protection against shorts in external wiring.
- Do not apply voltages exceeding the rated input voltage to Input Units. The Input Units may be destroyed.
- Do not apply voltages exceeding the maximum switching capacity to Output Units. The Output Units may be destroyed.
- Always disconnect the LG terminal when performing withstand voltage tests.
- Install all Units according to instructions in the operation manuals. Improper installation may cause faulty operation.
- Provide proper shielding when installing in the following locations:
  - Locations subject to static electricity or other sources of noise.
  - Locations subject to strong electromagnetic fields.
  - Locations subject to possible exposure to radiation.
  - Locations near to power supply lines.
- Be sure to tighten Backplane screws, terminal screws, and cable connector screws securely.
- Do not attempt to take any Units apart, to repair any Units, or to modify any Units in any way.

-  **Caution** The following precautions are necessary to ensure the general safety of the system. Always heed these precautions.

- Provide double safety mechanisms to handle incorrect signals that can be generated by broken signal lines or momentary power interruptions.
- Provide external interlock circuits, limit circuits, and other safety circuits in addition to any provided within the PC to ensure safety.

# SECTION 1

## Introduction

The C500-NC222-E Position Control Unit (PCU) in NC221 mode is a Special I/O Unit that receives positioning commands from the Programmable Controller (PC) and outputs control voltages to two servomotor drivers. Since it outputs control voltages rather than pulses, it can be directly connected to any of a variety of servomotor drivers. You can use it with the C500, C1000H, or C2000H PC.

Each of the two servomotor drivers controls a servomotor which rotates one of the two positioning axes. The Position Control Unit can control the axes independently or simultaneously. Both straight-line and circular arc interpolation are also possible.

This section describes the basic features, components, and operation of the Position Control Unit in NC221 mode, as well as the basic configuration and principles of positioning control systems. Reading this section first will give you a familiarity with the essential terminology used in this manual and an understanding of the fundamentals necessary for successful operation.

1-1	Features .....	2
1-2	Basic Operating Principles .....	2
1-3	Operational Flow .....	4
1-4	System Configuration .....	5
1-5	Control System Configuration .....	6
1-6	Control System Principles .....	6
1-7	Precautions When Using C500-NC222-E in NC221 Mode .....	10

## 1-1 Features

<b>Applicable Motor Drivers</b>	A control output voltage range from $-10\text{ V}$ to $+10\text{ V}$ enables connection to various servomotor drivers.
<b>Number of Control Axes and Controlling Capacity</b>	The Position Control Unit is designed to control two axes. Data configuration consisting of parameters, speeds, dwell times, acceleration and deceleration times, and positioning actions permits straight-line interpolation or circular arc interpolation by simultaneous dual-axis operation. Each motor axis may also be operated independently.
<b>Error Diagnostics</b>	Troubleshooting is facilitated by error code transmission from the Position Control Unit to the PC as well as by error code display on the External Display.
<b>Large Data Capacity with Backup</b>	The data capacity in the Position Control Unit provides 300 positioning actions per axis, 19 parameters per axis, 100 speeds, 10 dwell times per axis, and 10 acceleration and deceleration times per axis. All data is stored in the built-in EEPROM for battery-free and maintenance-free backup. Data is read into the RAM from the EEPROM when power is turned ON.
<b>Teaching Box</b>	Connecting the Teaching Box permits position inputs, position input reading, teaching inputs, and operation monitoring.
<b>High-speed Communications Between PC and PCU</b>	All data and command communications between the Programmable Controller and Position Control Unit use PC Intelligent I/O Read and Write instructions permitting high-speed processing.
<b>Applicable CPUs</b>	The C500-NC222-E Position Control Unit in NC221 mode can be used with a C500, C1000H, or C2000H PC. The C500-CPU11-EV1 CPU can be used with the C500, CVM1, CV500, CV1000, or CV2000 PC. Any C1000H and C2000H CPU may be used.

## 1-2 Basic Operating Principles

The basic operation of the C500-NC222-E Position Control Unit is fairly simple. It controls a servomotor driver in accordance with data stored in its memory. This data includes parameters, speeds, positions, and other information necessary for effective control. Before the Position Control Unit can be operated, you must first input the essential data. This is generally done via the Teaching Box.

The way in which the Position Control Unit makes use of this data is determined by the program in the PC. The program does not control all of the Position Control Unit's operations directly, but rather, transfers commands to the Position Control Unit for execution. The commands control such functions as the starting and stopping of positioning, returning to the origin, and so on. Thus, while the Position Control Unit functions as an integral part of your overall control system, it also exercises a good deal of autonomy. This capability is essential to the concept of distributed control, whereby control of each portion of an automated system is located near the devices actually being controlled.

The fundamental unit of positioning is the positioning action. A particular positioning action moves the workpiece along the axis in a direction, at a speed, and to a position determined by the data which has been set specifically for the positioning action. The positioning action begins when the start command is transferred by the PC program (XSRT, YSRT, or ISRT, depending on whether you want to position along the X axis, the Y axis, or both simultaneously). Before beginning execution of positioning actions, it is necessary to define the origin as a reference point by, for example, executing origin search (XORG, YORG, or IORG). The origin is simply the point which is designated as 0 at any given time. Positioning actions are described in detail in *3-4 Setting Positioning Actions*, using commands to start positioning actions is described in *6-5 SRT (Start) Commands and Positioning Actions*, and using commands with the origin is described in *Section 7 Establishing the Origin*.

# 1-3 Operational Flow

Positioning operations generally involve the following steps.

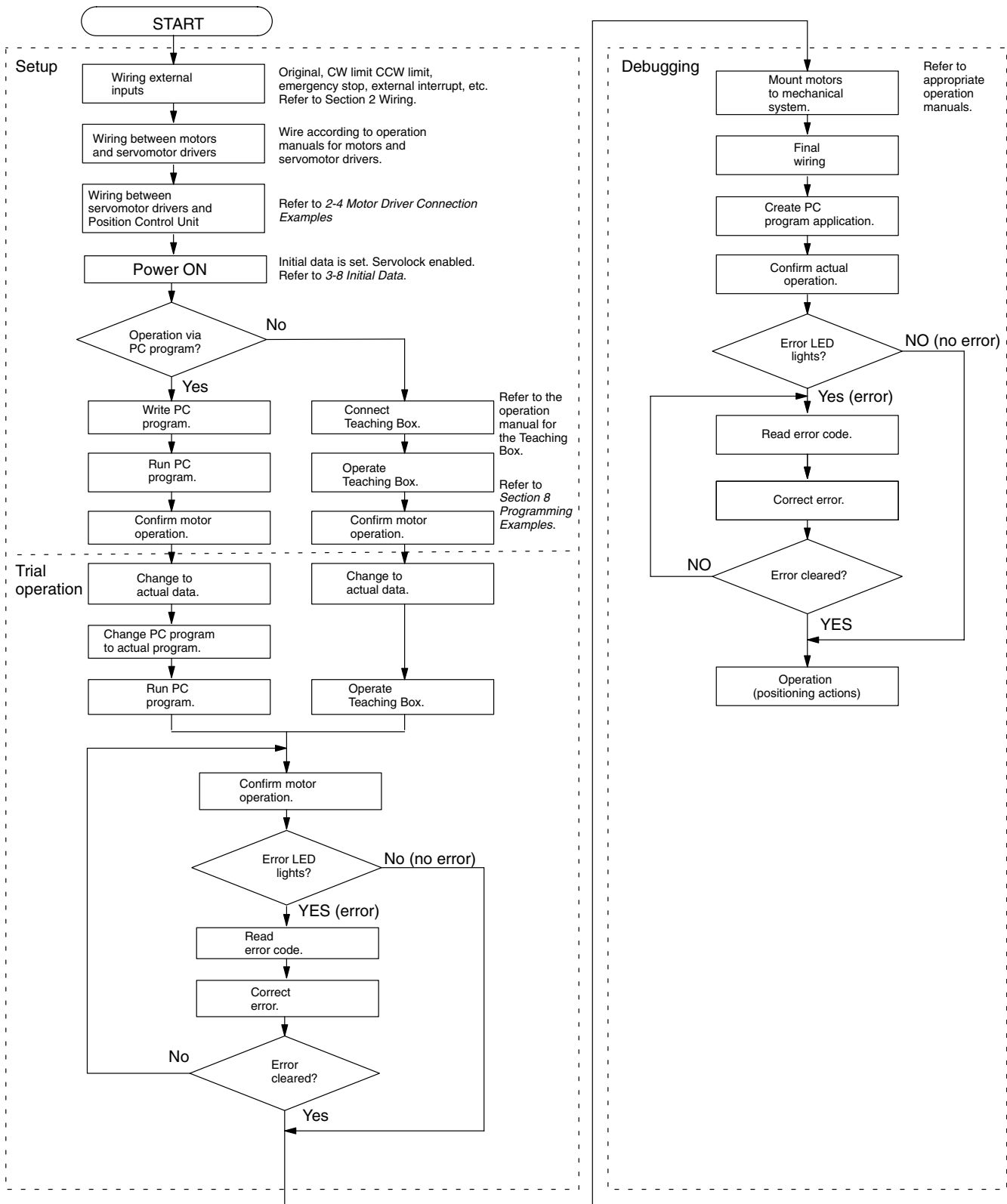

# 1-4 System Configuration

The following configuration illustrates example connections for a working system.

**Note** The Position Control Unit cannot be used if mounted to a Slave Rack.

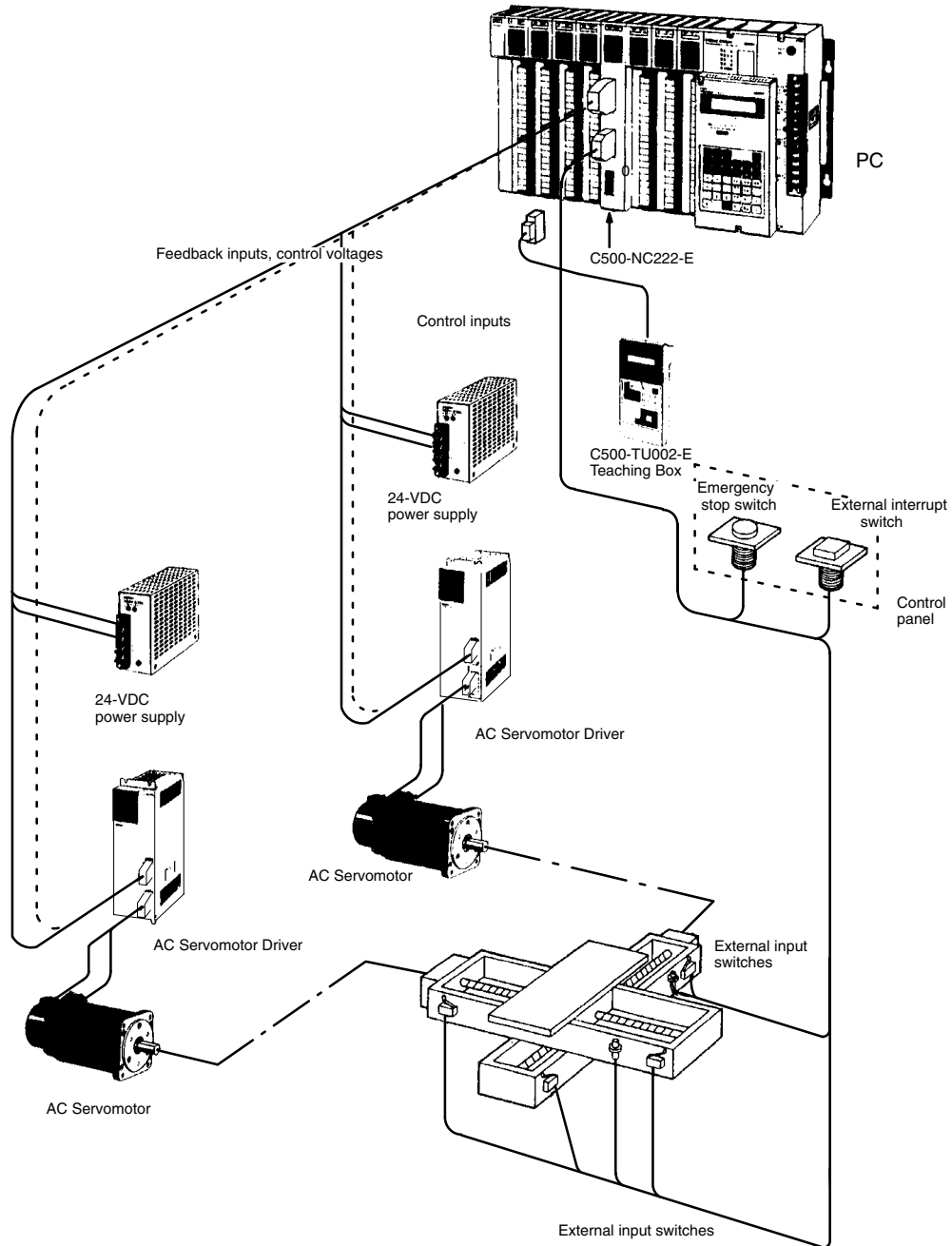



## 1-5 Control System Configuration

The following block diagram shows a control system for a servomotor driver. The Position Control Unit is arranged in a semiclosed-loop system.

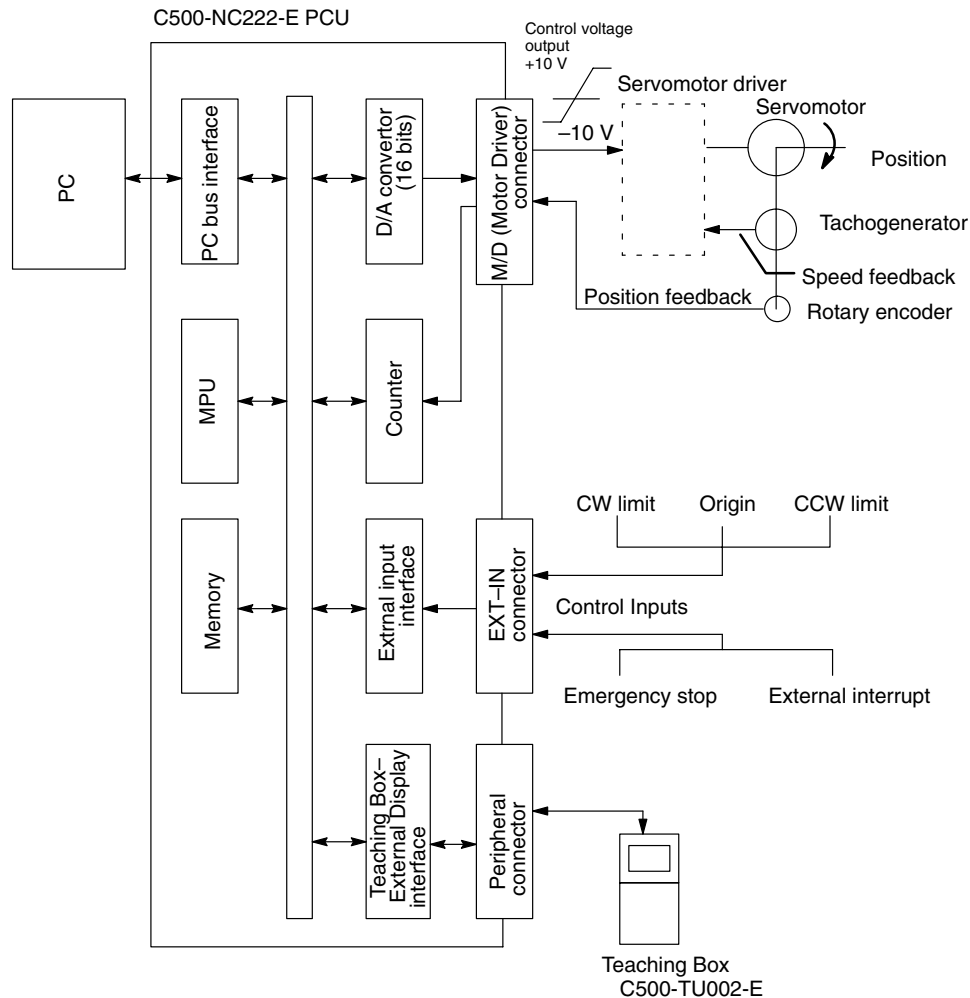

## 1-6 Control System Principles

### Open-loop Systems

Control systems can be quite simple or relatively complex. The most basic is an open-loop system, in which a particular operation is carried out, according to programmed instructions, but in which no feedback is provided for automatic adjustments.

### Closed-loop Systems

In a closed-loop system, PC controls an external process without human intervention. The servomotor provides direct feedback so that actual values (of positions, speeds, and so on) are continuously adjusted to bring them more closely in line with target values. The digital feedback signals are commonly transmitted to a digital-to-analog converter to complete the feedback loop, thereby permitting automated control of the process.

### Semiclosed-Loop Systems

The C500-NC222-E Position Control Unit is designed for use in a semiclosed-loop system. A semiclosed-loop system is similar to a closed-loop system, except that feedback is provided by a tachogenerator and a rotary encoder rather than directly by the servomotor. This system, which also in-

cludes an error counter, a D/A converter, and a servomotor driver, detects machine movements by rotation of the motor in relation to the target, computes the error between the target value and actual movement, and zeroes the error through feedback.

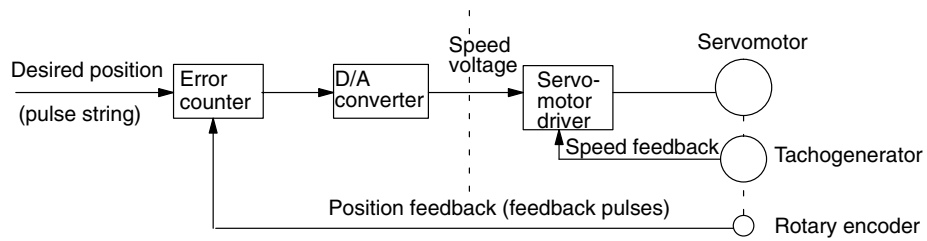

**Position Control Unit Action**

1. First, the error counter receives a target position in units of encoder pulses. The error counter transfers its contents to the D/A converter which converts the contents to analog speed voltages for the servomotor driver.

**Servomotor Driver Speed Characteristics**

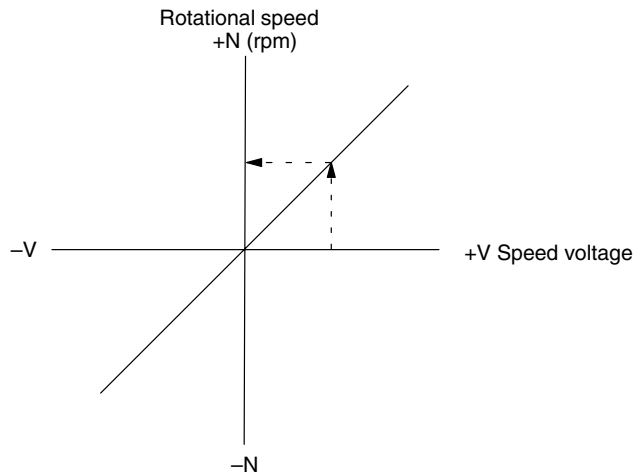

- The motor rotates at a speed corresponding to the speed voltage. The rotary encoder connected to the motor axis rotates in sync with the motor, generates feedback pulses, and subtracts error counter contents.

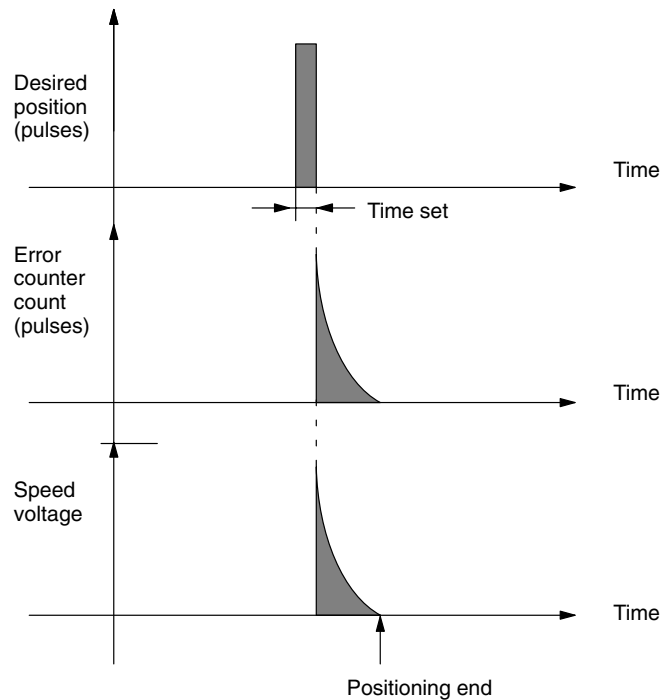

- Consequently, the encoder rotation is equivalent to the target position, and the motor stops rotating when the error counter count and the speed voltage becomes zero (stopping motor rotation).
- While the motor is stopped, the rotary encoder constantly maintains the stopped position through correction. If the motor axis moves slightly, the error counter receives a feedback pulse from the rotary encoder and a rotation voltage is emitted in the reverse direction, causing the motor to rotate toward its original position. This operation is called servolock or servoclamp.

- In order to execute positioning by the semiclosed-loop method with acceleration and deceleration, target positions are set consecutively in the error counter for processing, thus enabling smooth acceleration and deceleration.

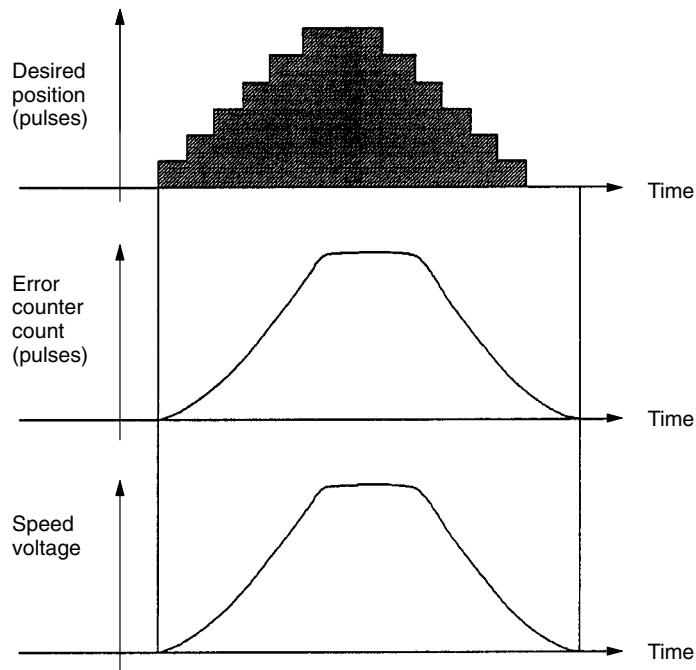

- The target position becomes the count for the error counter and controls the motor by conversion to a speed voltage for the servomotor driver. Thus, the position equals the total count of target positions (shaded area in the figure), and the speed will depend on the desired position per unit time.

**Simplified Positioning System Design**

Consider the following positioning system where millimeter is selected as the unit:

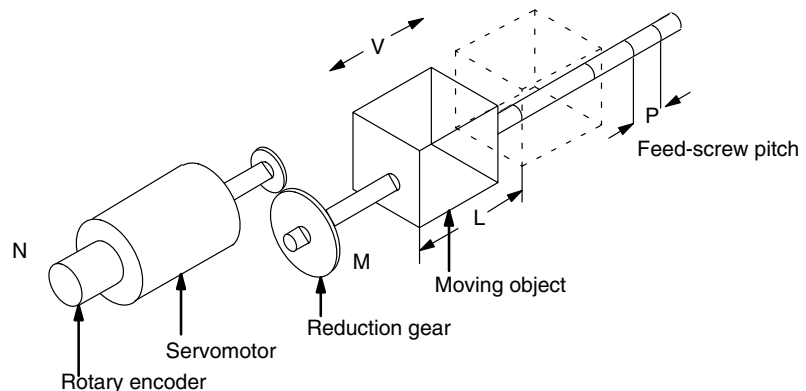

- Where:
- N = rotary encoder resolution (pulse/rev)
  - M = reduction ratio
  - V = speed of moving object (mm/s)
  - P = feed-screw pitch (mm/rev)
  - L = distance moved (mm)

Here,

$$\begin{aligned} \text{Positioning precision} &= \frac{\text{Feed-screw pitch}}{\text{Encoder pulses} \times \text{reduction ratio}} \\ &= \frac{P \text{ (mm/rev)}}{N \text{ (pulse/rev)} \times M} = \frac{P}{N \times M} \text{ (mm/pulse)} \end{aligned}$$

The positioning precision is called the pulse rate. Next, the required pulse speed from the encoder is:

$$\begin{aligned} \text{Required pulse speed} &= \frac{\text{Feeding speed}}{\text{Pulse rate}} = \frac{V \text{ (mm/s)}}{\text{Pulse rate (mm/pulse)}} \\ &= \frac{V \times N \times M}{P} \text{ (pulses)} \end{aligned}$$

For a movement of L mm:

$$\text{Requisite no. of pulses} = \frac{\text{Distance moved}}{\text{Pulse rate}} = \frac{L / P}{N \times M} = \frac{N \times M \times L}{P} \text{ (pulses)}$$

## 1-7 Precautions When Using C500-NC222-E in NC221 Mode

The C500-NC222-E in NC221 mode is different from the C500-NC221-E in the following points.

### 1, 2, 3... 1. Internal Control Cycle

The internal control cycle of the C500-NC222-E in NC221 mode is different from that of the C500-NC221-E. Accordingly, the output distribution cycle and external input read timing of the C500-NC222-E in NC221 mode are different from those of the C500-NC221-E.

#### Control Cycle

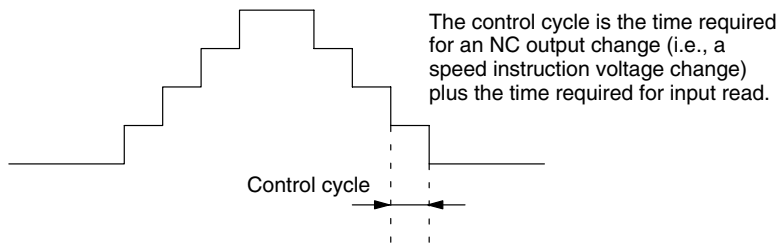

Control Cycle:

C500-NC221-E: 3.2 ms

C500-NC222-E in NC221 mode: 4.0 ms

### 2. Difference in Operation Due to Changes in Internal Control Cycle

Due to the difference of the internal control cycle of the C500-NC222-E in NC221 mode and that of the C500-NC221-E, the tact time (i.e., the time required for the whole positioning operation) of the C500-NC221-E is sometimes different from that required by the C500-NC222-E in NC221 mode.

There will be no timing errors if the C500-NC222-E in NC221 mode and the C500-NC221-E are in correct timing control operation, which however, does not mean that there is no difference in tact time between the C500-NC221-E and the C500-NC222-E in NC221 mode.

**Change in Tact Time**

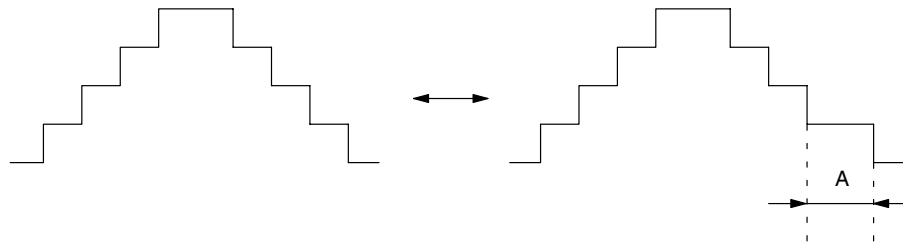

There is no difference in movement range between the C500-NC222-E in NC221 mode and the C500-NC221-E. The period A, which is the value left over by the internal operation of the C500-NC222-E in NC221 mode as shown in the above timing chart on the right hand side, however, may be produced. The difference in tact time is caused by the period A, which can be, however, solved by adjusting the speed data or movement range of the C500-NC222-E.

**3. Parameter Settings Before Shipping**

The parameters of the C500-NC222-E are factory-set so that the C500-NC222-E can be used in NC222 mode. NC221 and NC222 mode parameters share the same area of the C500-NC222-E. Therefore, before using the C500-NC222-E in NC221 mode, be sure to change the parameters. Refer to the following table for the differences between NC221 and NC222 mode parameters.

	Address	Type	Initial data and data attributes		
			NC221	NC221 mode	NC222
X-axis test data	100	X-axis test data 1	Position data: 500 pulses; speed data: 1; M code: 01; dwell timer: 5; ABS; Pattern: 0; acceleration and deceleration pattern: 5	Position data: 1,000 pulses; speed data: 1; M code: 01; dwell timer: 5; ABS; Pattern: 0; acceleration and deceleration pattern: 5	Position data: 1,000 pulses; speed data: 1; M code: 01; dwell timer: 5; ABS; Pattern: 0; acceleration and deceleration pattern: 5
	101	X-axis test data 2	Position data: -500 pulses; speed data: 3; M code: 02; dwell timer: 0; INC; Pattern: 1; acceleration and deceleration pattern: 0	Position data: -1,000 pulses; speed data: 3; M code: 02; dwell timer: 0; INC; Pattern: 1; acceleration and deceleration pattern: 0	Position data: 1,000 pulses; speed data: 3; M code: 02; dwell timer: 0; INC; Pattern: 1; acceleration and deceleration pattern: 0
	102		Position data: -500 pulses; speed data: 2; M code: 03; dwell timer: 5; ABS; Pattern: 1; acceleration and deceleration pattern: 2	Position data: -1,000 pulses; speed data: 2; M code: 03; dwell timer: 5; ABS; Pattern: 1; acceleration and deceleration pattern: 2	Position data: 1,000 pulses; speed data: 2; M code: 03; dwell timer: 5; ABS; Pattern: 1; acceleration and deceleration pattern: 2
	103		Position data: -500 pulses; speed data: 1; M code: 04; dwell timer: 1; INC; Pattern: 0; acceleration and deceleration pattern: 1	Position data: -1,000 pulses; speed data: 1; M code: 04; dwell timer: 1; INC; Pattern: 0; acceleration and deceleration pattern: 1	Position data: 1,000 pulses; speed data: 1; M code: 04; dwell timer: 1; INC; Pattern: 0; acceleration and deceleration pattern: 1
	104	X/Y-axis test data 1	Position data: 0 pulses; speed data: 1; M code: 05; dwell timer: 1; ABS; acceleration and deceleration pattern: 1; interpolation end point	Position data: 0 pulses; speed data: 1; M code: 05; dwell timer: 1; ABS; acceleration and deceleration pattern: 1; interpolation end point	Position data: 0 pulses; speed data: 1; M code: 05; dwell timer: 1; ABS; acceleration and deceleration pattern: 1; interpolation end point
X-axis parameter data	400	Unit setting	0	0	0
	401	Pulse rate	1	1	1
	402	Rotating direction	0	0	0
	403	Encoder type	01	01	001
	404	Gain	200	200	200
	405	In-position zone	10	10	10
	406	Backlash compensation	0	0	0
	407	Stroke limit (+)	999999	999999	999999
	408	Stroke limit (-)	999999	999999	999999
	409	Zone setting	01000100	01000100	01000100
	410	Home shift	0	0	0
	411	Maximum speed	10000	FFFFFFFF (*1: see note)	40010000
412	Jog forward maximum speed	2000	FFFFFFFF (*2: see note)	10002000	

	Address	Type	Initial data and data attributes		
			NC221	NC221 mode	NC222
X-axis parameter data	413	Origin search direction	0	0	0
	414	Origin compensation	0	0	0
	415	Origin search maximum speed	5000	5000	5000
	416	Origin search acceleration and deceleration	5	5	5
	417	Origin search low speed	1000	1000	1000
	418	Deceleration stop pulse number	500	500	00000500
	419	Wiring check function	---	---	01100011
		Emergency stop counter capacity	0	7024	---
	420	External output control setting	00032768	00032768	00032768
Dwell timer	450/850	Dwell timer 0	0	-1	0
	451/851	Dwell timer 1	100	-1	100
	452/852	Dwell timer 2	200	-1	200
	453/853	Dwell timer 3	300	0	300
	454/854	Dwell timer 4	400	100	400
	455/855	Dwell timer 5	500	200	500
	456/856	Dwell timer 6	600	0	600
	457/857	Dwell timer 7	700	100	700
	458/858	Dwell timer 8	800	200	800
	459/859	Dwell timer 9	900	300	900
Acceleration and deceleration pattern	460/860	Acceleration and deceleration pattern 0	00100010	00000400	00100010
	461/861	Acceleration and deceleration pattern 1	00100020	00000500	00100020
	462/862	Acceleration and deceleration pattern 2	00100030	00000600	00100030



	Address	Type	Initial data and data attributes		
			NC221	NC221 mode	NC222
Acceleration and deceleration pattern	463/863	Acceleration and deceleration pattern 3	00100040	00000700	00100040
	464/864	Acceleration and deceleration pattern 4	00100050	00000800	00100050
	465/865	Acceleration and deceleration pattern 5	00200020	00000900	00200020
	466/866	Acceleration and deceleration pattern 6	00200030	00100010	00200030
	467/867	Acceleration and deceleration pattern 7	00200040	00100020	00200040
	468/868	Acceleration and deceleration pattern 8	00200050	00100030	00200050
	469/869	Acceleration and deceleration pattern 9	00200060	00100040	00200060
Y-axis test data	500	Y-axis test data 1	Position data: 500 pulses; speed data: 1; M code: 06; dwell timer: 5; INC; Pattern: 0; acceleration and deceleration pattern: 5	Position data: 1,000 pulses; speed data: 1; M code: 06; dwell timer: 5; INC; Pattern: 0; acceleration and deceleration pattern: 5	Position data: 10,000 pulses; speed data: 1; M code: 06; dwell timer: 5; INC; Pattern: 0; acceleration and deceleration pattern: 5
	501	Y-axis test data 2	Position data: 0 pulses; speed data: 1; M code: 07; dwell timer: 0; ABS; Pattern: 1; acceleration and deceleration pattern: 0	Position data: 0 pulses; speed data: 3; M code: 07; dwell timer: 0; ABS; Pattern: 1; acceleration and deceleration pattern: 0	Position data: 0 pulses; speed data: 3; M code: 07; dwell timer: 0; ABS; Pattern: 1; acceleration and deceleration pattern: 0
	502		Position data: -500 pulses; speed data: 2; M code: 08; dwell timer: 5; INC; Pattern: 1; acceleration and deceleration pattern: 2	Position data: -1,000 pulses; speed data: 2; M code: 08; dwell timer: 5; INC; Pattern: 1; acceleration and deceleration pattern: 2	Position data: 1,000 pulses; speed data: 2; M code: 08; dwell timer: 5; INC; Pattern: 1; acceleration and deceleration pattern: 2
	503		Position data: -1,000 pulses; speed data: 3; M code: 09; dwell timer: 0; ABS; Pattern: 0; acceleration and deceleration pattern: 1	Position data: -1,000 pulses; speed data: 1; M code: 09; dwell timer: 0; ABS; Pattern: 0; acceleration and deceleration pattern: 1	Position data: -2,000 pulses; speed data: 1; M code: 09; dwell timer: 0; ABS; Pattern: 0; acceleration and deceleration pattern: 1
	504	X/Y-axis test data 1	Position data: 0 pulses; speed data: 1; M code: 10; dwell timer: 1; ABS; acceleration and deceleration pattern: 1; interpolation end point	Position data: 0 pulses; speed data: 1; M code: 10; dwell timer: 1; ABS; acceleration and deceleration pattern: 1; interpolation end point	Position data: 0 pulses; speed data: 1; M code: 10; dwell timer: 1; ABS; acceleration and deceleration pattern: 1; interpolation end point

	Address	Type	Initial data and data attributes		
			NC221	NC221 mode	NC222
Y-axis parameter data	800	Unit setting	0	0	0
	801	Pulse rate	1	1	1
	802	Rotating direction	0	0	0
	803	Encoder type	01	01	001
	804	Gain	200	200	200
	805	In-position zone	10	10	10
	806	Backlash compensa- tion	0	0	0
	807	Stroke limit (+)	999999	999999	999999
	808	Stroke limit (-)	999999	999999	999999
	809	Zone setting	01000100	01000100	01000100
	810	Home shift	0	0	0
	811	Maximum speed	10000	FFFFFFFF (*1: see note)	40010000
	812	Jog forward maximum speed	2000	FFFFFFFF (*2: see note)	10002000
	813	Origin search direc- tion	0	0	0
	814	Origin comp- ensation	0	0	0
	815	Origin search maxi- mum speed	5000	5000	5000
	816	Origin search acceleration and decel- eration	5	5	5
	817	Origin search low speed	1000	1000	1000
	818	Deceleration stop pulse number	500	500	00000500
	819	Wiring check function	---	---	01100011
Emergency stop counter capacity		0	7024	---	
820	External out- put control setting	00032768	00032768	00032768	

	Address	Type	Initial data and data attributes		
			NC221	NC221 mode	NC222
Speed data	900	Speed data 0	10000	10000	10000
	901	Speed data 1	1000	1000	1000
	902	Speed data 2	2000	2000	2000
	903	Speed data 3	3000	3000	3000
	904	Speed data 4	4000	4000	4000
	905	Speed data 5	5000	5000	5000
	906	Speed data 6	6000	6000	6000
	907	Speed data 7	7000	7000	7000
	908	Speed data 8	8000	8000	8000
	909	Speed data 9	9000	9000	9000

**Note** The Teaching Unit displays the following in the above \*1) and \*2) cases.

\*1: OVER\_PS

\*2: JOG OVER\_PS

## **SECTION 2**

### **Wiring**

2-1	M/D Connector .....	18
2-2	EXT-IN Connector .....	21
2-3	Faulty Wiring Diagnostic Function .....	22
2-4	Motor Driver Connection Examples .....	24
2-5	Wiring Precautions .....	26

## 2-1 M/D Connector

The M/D (motor driver) connector is used for wiring servomotor driver I/O. Control voltage outputs and feedback pulse inputs go through here. The connector type and pin layouts are shown below.

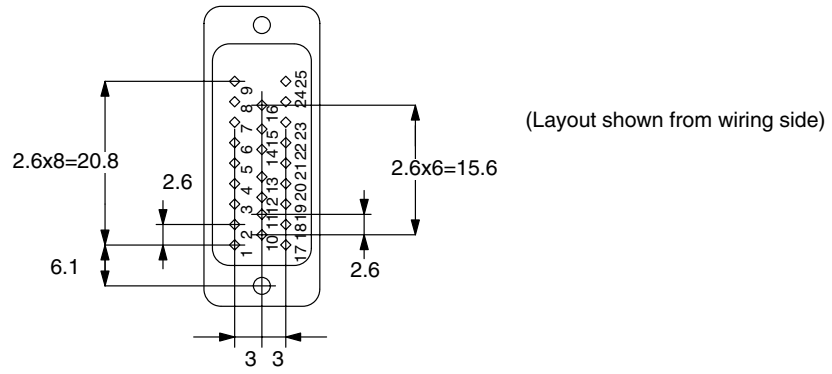

## Pin Terminal Functions

Pin No.	Symbol	Name	Description
1	DC GND	0 V	0-V terminal for pins 11 and 12
2	OUT-2X	X-axis OUT2 output	User defined output (for X axis)
3	OUT-1X	X-axis OUT1 output	
4	X- $\bar{B}$	X-axis Phase $\bar{B}$ input	Phase $\bar{B}$ feedback input for X axis
5	X-B	X-axis Phase B input	Phase B feedback input for X axis
6	X- $\bar{A}$	X-axis Phase $\bar{A}$ input	Phase $\bar{A}$ feedback input for X axis
7	X-A	X-axis Phase A input	Phase A feedback input for X axis
8	XAG	X-axis speed 0 V	0-V output for X-axis speed voltage to servomotor driver
9	XOUT	X-axis speed	X-axis speed voltage output to servomotor driver
10	FG	Frame ground	Ground terminal
11	+24V	24 V for OUT output	+24 VDC input terminal for OUT output
12	+24V		
13	Y- $\bar{Z}$	Y-axis phase $\bar{Z}$ input	Phase $\bar{Z}$ feedback input for Y axis
14	Y-Z	X-axis phase Z input	Phase Z feedback input for Y axis
15	X- $\bar{Z}$	X-axis phase $\bar{Z}$ input	Phase $\bar{Z}$ feedback input for X axis
16	X-Z	Y-axis phase Z input	Phase Z feedback input for X axis
17	DC GND	0 V	0-V terminal for pins 18 and 19
18	OUT 2Y	Y-axis OUT2 output	User defined output (for Y axis)
19	OUT 1Y	Y-axis OUT1 output	
20	Y- $\bar{B}$	Y-axis Phase $\bar{B}$ input	Phase $\bar{B}$ feedback input for Y axis
21	Y-B	Y-axis Phase B input	Phase B feedback input for Y axis
22	Y- $\bar{A}$	Y-axis Phase $\bar{A}$ input	Phase $\bar{A}$ feedback input for Y axis
23	Y-A	Y-axis Phase A input	Phase A feedback input for Y axis
24	YAG	Y-axis speed 0 V	0-V output for Y-axis speed voltage to servomotor driver
25	YOUT	Y-axis speed instruction	Y-axis speed voltage output to servomotor driver

**Input Circuits (Feedback Inputs for Phases A, B, and Z)**

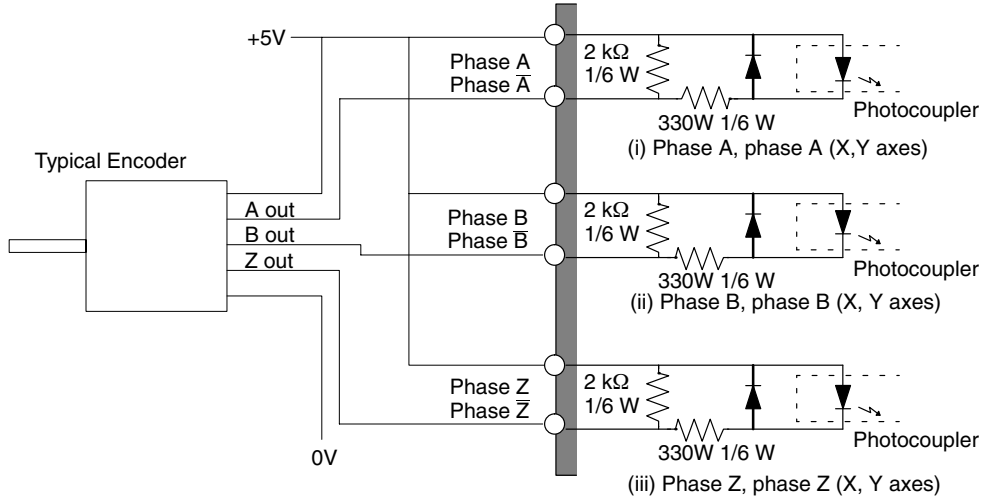

**Output Circuitry (OUT Outputs and Speeds)**

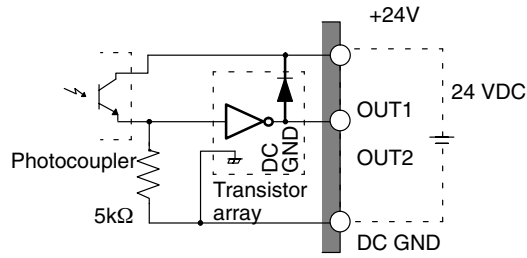

OUT1/OUT2 outputs (X, Y axes)

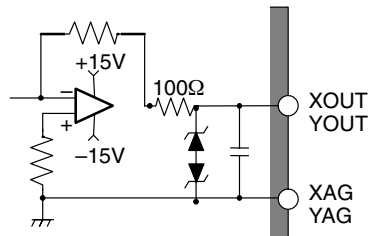

OUT/AG outputs (X, Y axes)

## 2-2 EXT-IN Connector

The EXT-IN (external input) connector is used for wiring external inputs. Since the C500-NC222-E Position Control Unit allows dual axis control, the EXT-IN connector provides inputs for both X and Y axes for connecting inputs from limit switches, from switches to stop the system, and from the mechanical origin. The connector type and pin layouts are shown below.

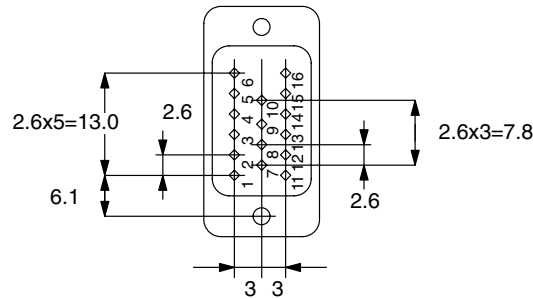

(Layout shown from connected side)

### Pin Functions

Pin No.	Symbol	Name	Description
1	DC GND	0 V	Ground (0 V) terminal for external 24-VDC power supply
2	CCWLX	X-axis CCW limit	Limit switch input for X-axis in CCW direction (NC)
3	STPX	X-axis external interrupt	Used for stopping X axis earlier than normal deceleration stop (NO). Active at its leading edge.
4	ORGX	X-axis origin	Used as X-axis mechanical origin (NO).
5	EMGX	X-axis emergency stop	Used to stop X axis in an emergency such as a run-away motor (NC).
6	CWLX	X-axis CW limit	Limit switch input for X axis in CW direction (NC)
7	FG	Frame ground	Ground terminal
8	+24V	24-V input	Positive (+24 V) terminal for external 24-VDC power supply
9	+24V		
10	–	–	Unused
11	DC GND	0 V	Ground (0 V) terminal for external 24-VDC power supply
12	CCWLY	Y-axis CCW limit	Limit switch input for Y axis in CCW direction (NC)
13	STPY	Y-axis external interrupt	Used for stopping Y axis earlier than normal deceleration-stop (NO). Active at its leading edge.
14	ORGY	Y-axis origin	Used as Y-axis mechanical origin (NO).
15	EMGY	Y-axis emergency stop	Used to stop Y axis in an emergency such as a run-away motor (NC).
16	CWLY	Y-axis CW limit input	Limit switch input for Y axis in CW direction (NC)



Configuration of Input Circuit

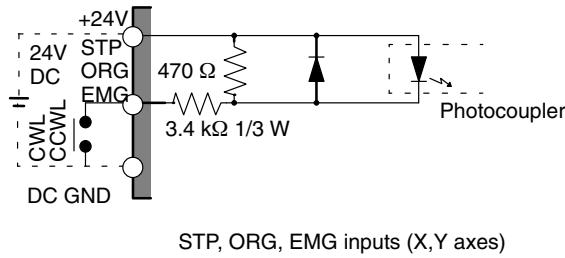

External Interrupt Inputs

External interrupt inputs are effective during operation, but their functions differ for 1) Positioning and searching for the origin and 2) JOG operations.

During positioning or origin searches, setting of positions into the error counter is stopped, and the count decreases naturally to cause a deceleration stop through workpiece momentum. This deceleration differs according to the degree of momentum in the error counter when the external interrupt is turned ON.

Similarly, during JOG operations the error counter count decreases naturally to cause a deceleration stop through workpiece momentum. However, during JOG operations natural deceleration occurs according to the number of pulses stored in the deceleration-stop parameter (address 418 for the X axis, 818 for the Y axis) whenever the setting of this parameter is larger than the value in the error counter when the external interrupt is received. In this capacity an external interrupt can be used to stop the workpiece after an established number of pulses.

Emergency Stop Input

If the emergency stop input is received while an axis is moving, pulse string input to the error counter will be stopped, the error counter will be cleared, positioning will stop immediately, and a servo lock will be set. When an emergency stop is executed, the current position will also be cleared.

To restart operation after an emergency stop has been executed, turn OFF the emergency stop input, reset the error (ERST), and redefine the origin.

## 2-3 Faulty Wiring Diagnostic Function

In a semiclosed-loop servo system, faulty wiring may cause the servomotor to run out of control. The Position Control Unit prevents this by its faulty wiring diagnostic function.

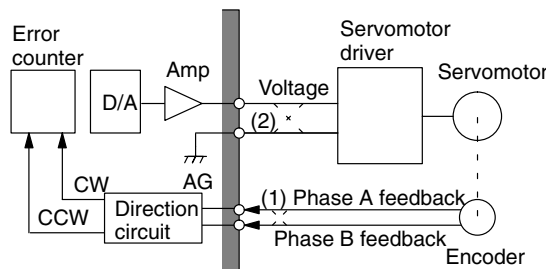

- (1) Faulty wiring at phase feedbacks A and B.
- (2) Faulty wiring at ground and positive lines of speed voltage output.

Under normal wiring conditions a position control loop is created when power is turned ON, and a servolock occurs. For example, if the motor rotates in the CW direction during servolock, the encoder will detect this. Consequently, feedback signals notify the error counter in the Position Control Unit about the direction and magnitude of this movement. Since the error counter count is ordinarily zero unless otherwise designated, even if the motor moves in the CW direction and the feedback signals transfer this direction and movement as a count to the error counter, it will zero this count figure by rotating the motor in the CCW direction with the appropriate control voltage. The control voltage is output to the servomotor driver, and the motor rotates in the CCW direction. Again, when the motor rotates in this CCW direction the encoder will detect the movement and notify the error counter in the Position Control Unit with feedback signals. This loop subtracts the count figure in the error counter to zero it. Hence, the creation of a position control loop and valid servolock will ordinarily allow the servomotor to constantly correct and maintain its stopped position.

If feedback input lines Phase A and Phase B are wired in reverse (broken lines at (1) in the figure), the servolock is ineffective and the motor runs out of control. Suppose the motor rotates in the CW direction and the encoder detects this. Because the feedback input wiring is reversed at the Position Control Unit, the error counter receives the information as a magnitude in the CCW direction. Then the error counter attempts to zero the count figure by a control voltage output in the CW direction. The reversed wiring thus causes further CW rotation when the servomotor driver receives this control voltage. The error counter continues to total a count in the CCW direction, and the motor runs out of control in the CW direction as the cycle repeats. This can occur not only from reversed wiring of Phases A and B of the feedback inputs, but also from reversed wiring of the speed voltage and the ground (zero volt) lines. Run-away motors are quite dangerous because they become apparent only after switching power on.

The C500-NC222-E Position Control Unit counters this danger with the following faulty wiring diagnostics in order to prevent run-away motors.

- When the power is turned ON the error counter capacity has a limit so that a control voltage beyond  $\pm 0.3$  V is not output.
- In the event of faulty wiring, this limit ensures that the motor will not run too fast to be stopped externally. Immediately check the wiring and parameters after the motor stops.
- This faulty wiring diagnostic function clears when the first axis operation command arrives such as SRT, JOG, PLS, ORG, etc. Thus during ordinary operation this limit does not interfere.
- If a motor does run away and the error counter overflows because of an error, stop the motor by a 0-V control voltage and clear the servolock function. Then immediately turn OFF the servomotor driver power supply since the motor may continue to move slowly under a 0-V drift.

Other reasons why the servolock does not engage and causes a run-away motor include 1) reversed connections of A and A or B and B, 2) faulty wiring between the servoamp and servomotor, or 3) incorrect rotation direction settings for parameters (addresses 402/802). Check for these if you suspect wiring problems.

## 2-4 Motor Driver Connection Examples

In this example for 1-axis control, proximity and limit switch connections are wired to be current-activated. Set OUT1 and OUT2 as needed.

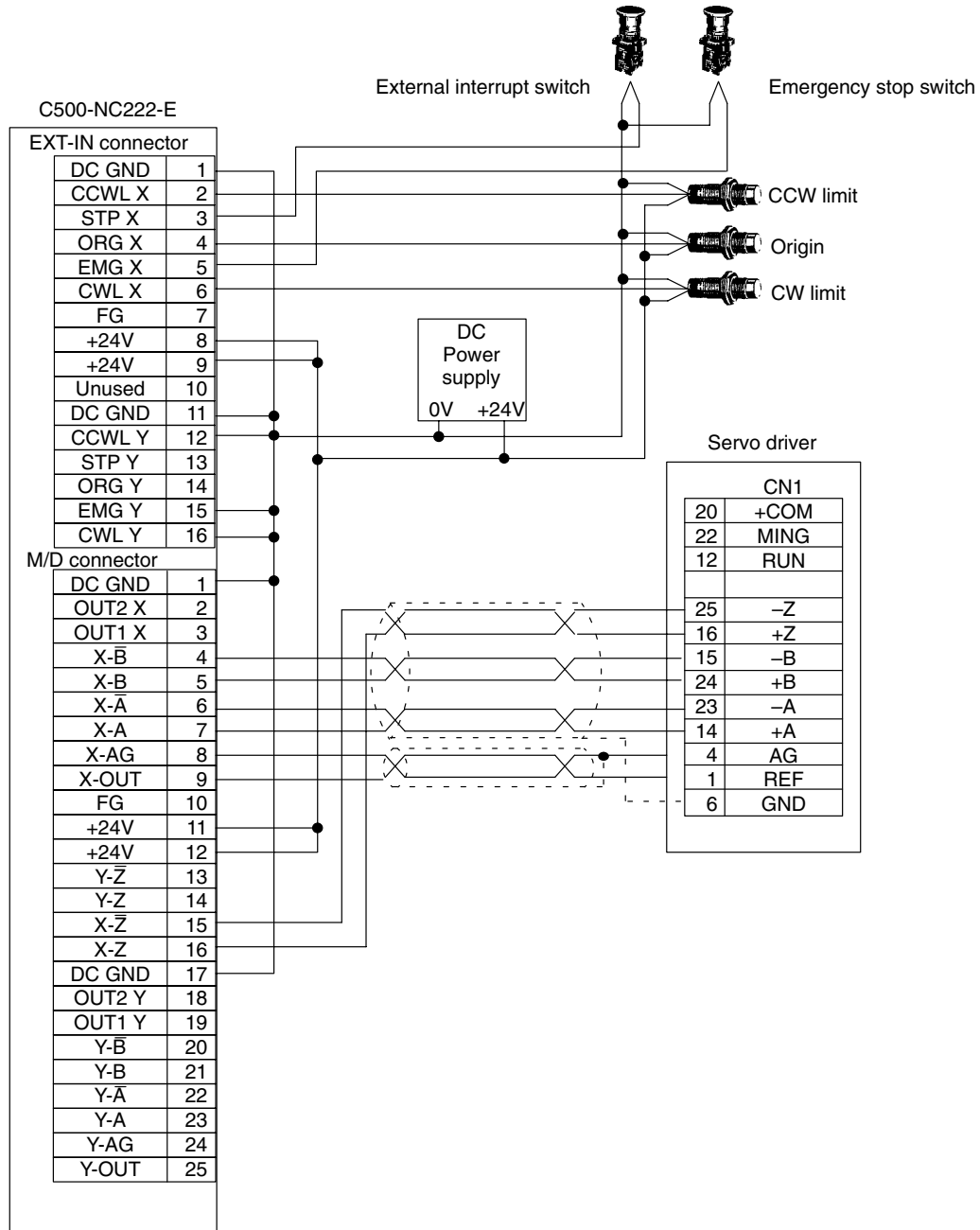

In this example for 1-axis control, proximity switch connections are wired to be current-opening. Set OUT1 and OUT2 as needed.

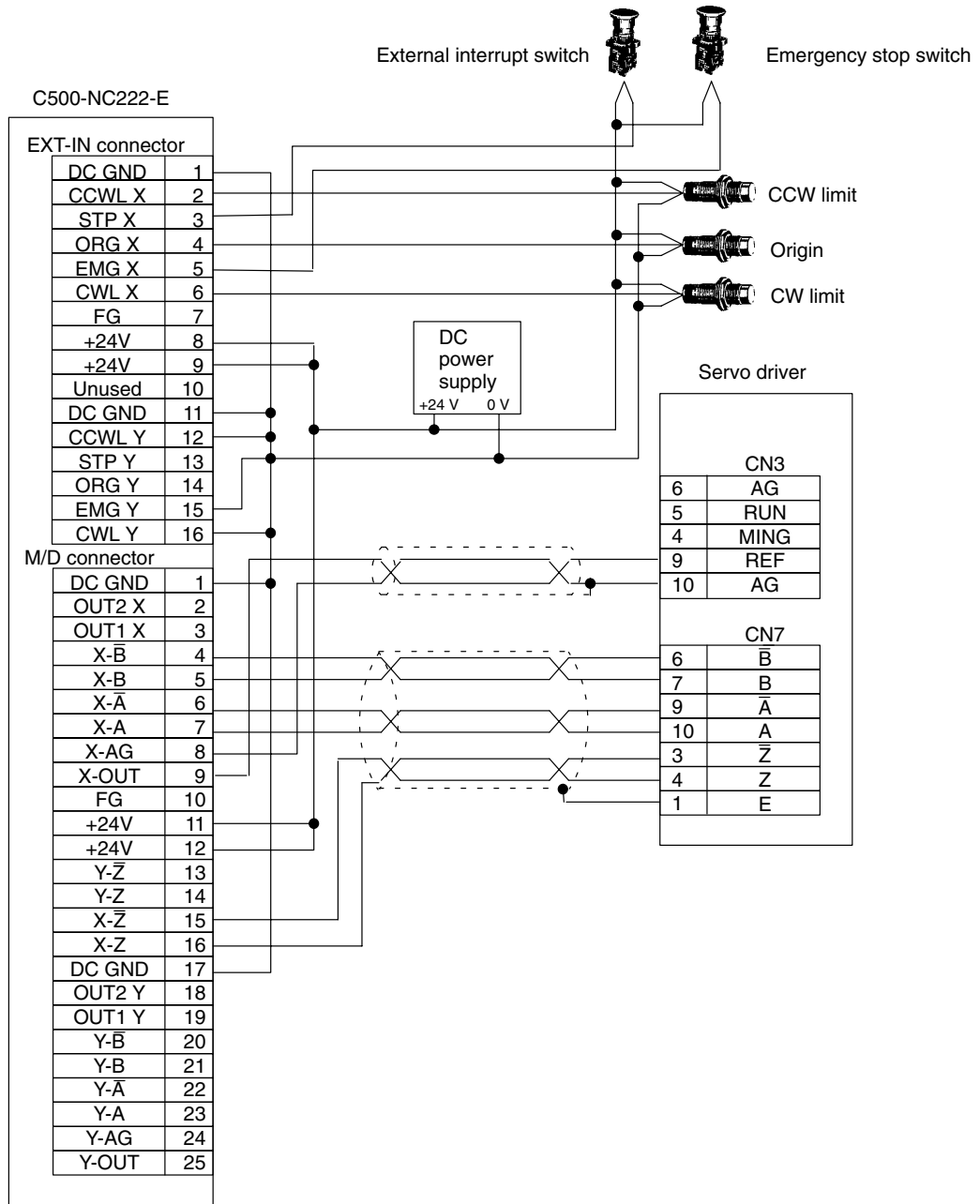

## 2-5 Wiring Precautions

Electronically controlled equipment may malfunction because of noise generated by power supply lines or external loads. Such malfunctions are difficult to reproduce; hence, determining the cause often requires a great deal of time.

The Position Control Unit is naturally susceptible to noise malfunction. The following tips, however, should aid in avoiding noise malfunction and improve system reliability.

- 1, 2, 3...**
1. Always use designated electrical cables.
  2. Separate power cables (AC power supply, motor power supply) and control cables (pulse outputs, external I/O). Do not group the two types together or place them in the same conduit.
  3. Control cables must be shielded.
  4. For inductive loads (relays, solenoids, solenoid valves), connect surge absorbing circuits. Connect surge absorbing components close to the relay or solenoid. For a DC relay, use a surge-absorbing diode with a voltage tolerance at least five times greater than the circuit voltage.

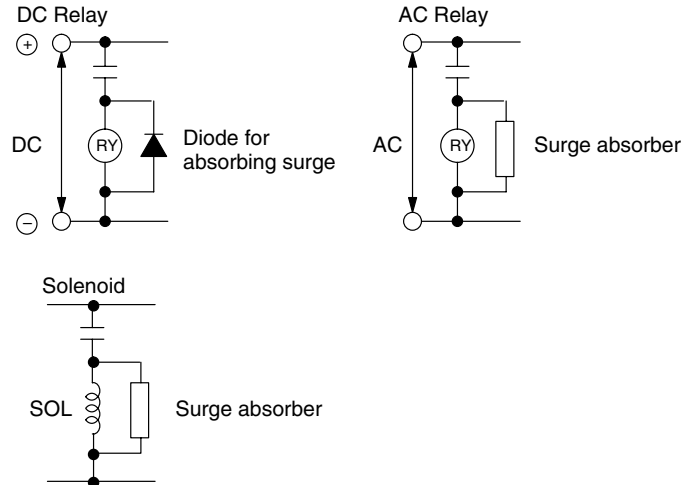

5. Noise from the power supply line (e.g., when using the same power supply with an electric welder or electrical discharge unit, or when a high-frequency noise generator is nearby) can be alleviated by inserting a noise filter at the power supply input.
6. Use twisted pair cable for power supply lines.
7. Use adequate grounds with a cross-section of 1.25 mm<sup>2</sup> or greater. Ground at a resistance no greater than 100 Ω.
8. The I/O terminals that operate the 24-V system are isolated with photo-couplers to reduce external noise effects on the control system. In accordance with this provision, avoid connections between the analog control voltage ground (AG) and 24-V ground (DC GND).

# SECTION 3

## Data Configuration

Before executing positioning actions, you must enter the necessary data into the EEPROM of the Position Control Unit. The C500-NC222-E Position Control Unit has a large data capacity. The EEPROM can store data for 300 positioning actions, 100 speeds, 19 parameters, 10 dwell times, and 10 acceleration and deceleration times per axis. You can set data most conveniently with the Teaching Box, but it is also possible to send data from the PC to the Position Control Unit.

Data is automatically transferred from EEPROM to RAM when the Position Control Unit is powered up. The commands transferred from the DM area of the PC (see *Section 6 Commands* for details) contain settings which access this data.

3-1	Overview .....	28
3-2	Data Allocations .....	29
3-3	Setting Parameters .....	30
3-4	Setting Positioning Actions .....	42
3-5	Setting Dwell Times .....	48
3-6	Setting Acceleration and Deceleration Times .....	48
3-7	Setting Speeds .....	49
3-8	Initial Data .....	50

## 3-1 Overview

The Position Control Unit (PCU) outputs control voltage pulses to motor drivers. The basic control unit, therefore, is the pulse; control voltages differ by the number of pulses they contain.

### Pulse Rate

Pulses are signals sent to motor drivers to command precise motor motion. In order to facilitate programming, the Teaching Box accepts input in units of pulses, millimeters (mm), or inches. The type of unit is set with the Teaching Box or PC and entered at parameter address 400 for the X axis and 800 for the Y axis. The magnitude of the pulse rate is entered at address 401 for the X axis and 801 for the Y axis.

The pulse rate is equivalent to dividing the movement,  $x$ , of an object attached to a motor by the number of pulses,  $n$ , required for this movement. The pulse rate thus equals  $x/n$ . In actual operation, the data input in normal units of distance is translated by the Teaching Box so the data is stored directly as pulses.

### Setting Data

The most convenient way to set data is with the Teaching Box. Specific memory areas in the Position Control Unit are designated for certain types of data. The data provides the precise information necessary to drive a stepping motor or servomotor through a number of specific motions. There are five types of data: parameters, speeds, dwell times, acceleration and deceleration times, and positioning actions. When setting data for the first time, you must set parameters first, followed by speeds, dwell times, acceleration and deceleration times, and then positioning actions.

## 3-2 Data Allocations

Commands, parameters, speeds, positioning actions, dwell times, and acceleration and deceleration times are stored at the following addresses. Positioning actions include the position, speed, and other attributes. Parameters categorically establish limits and directions for positioning actions.

Data	PCU Address	No. of PC Words	Description	Permitted Settings
Positioning actions	100 to 399	5	For the X axis	$\pm 99,999,999$ pulses (for desired position)
Parameters	400	2	Unit	0 to 2
	401	3	Pulse rate	$(1 \text{ to } 10,000) \times 10^{-4}$ (unit/pulse)
	402	2	Rotation direction	0 or 1
	403	2	Encoder type	0 or 1 and 1, 2, 4
	404	2	Gain	$(1 \text{ to } 999) \times 10 \mu\text{V/pulse}$
	405	2	In-position zone	1 to 999 pulses
	406	2	Backlash compensation	0 to 9,999 pulses
	407	3	Stroke limit (+)	0 to 99,999,999 pulses
	408	3	Stroke limit (-)	0 to 99,999,999 pulses
	409	3	Zone setting	0 to 9,999 pulses
	410	3	Home shift	$\pm 999,999$ pulses
	414	3	Maximum speed	1 to 300,000 pps
	412	3	Maximum jogging speed	1 to 300,000 pps
	413	2	Origin search direction	0 or 1
	414	3	Origin compensation	$\pm 999,999$ pulses
	415	3	High origin search speed	1 to 300,000 pps
	416	2	Origin search accel./decel.	0 to 9
	417	3	Low origin search speed	1 to 10,000 pps
418	3	Deceleration stop	1 to 10,000 pulses	
Dwell times	450 to 459	2	For the X axis	0 to 9,990 ms (in 10-ms increments)
Acceleration/Deceleration	460 to 469	3	For the X axis	10 to 4,990 ms (in 10-ms increments)
Positioning	500 to 799	5	For the Y axis	$\pm 99,999,999$ pulses (for desired position)
Parameters	800 to 818	2 or 3	For the Y axis; analogous to 400 to 418 for X axis	–
Dwell times	850 to 859	2	For the Y axis	0 to 9,990 ms (in 10-ms increments)
Acceleration/Deceleration	860 to 869	3	For the Y axis	10 to 4,990 ms (in 10-ms increments)
Speeds	900 to 999	3	Speeds for both axes	1 to 300,000 pps (in 1-pps increments)



### 3-3 Setting Parameters

When writing data into the Position Control Unit for the first time, you must start with parameters. The word *parameters*, as used here, has a rather specific meaning and refers to certain data settings (described below) which delineate particular aspects of operation. Each parameter is allocated either two or three 16-bit words in the EEPROM. The first of these words is always used to designate the address. The remaining one or two words are used to write data specific to that particular parameter. You must write two sets of data (one for each axis) for each parameter.

In the following explanations, the addresses for both axes are listed for each parameter. The table above provides a comprehensive listing of addresses. Default settings refer to the initial data loaded for the trial operation. See *Section 3-8* for a comprehensive listing of initial data settings.

**Note** The following data is for setup within the PC for transfers. If the Teaching Box is used, see operation manual W145. The data within the parenthesis contains the PCU address for the data being described.

**Unit (X axis: 400, Y axis: 800)**

Designates the unit to be used with the Teaching Box (C500-TU002-E) and External Display (C500-ND201).

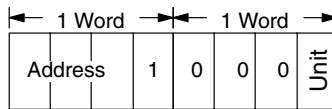

Pulse: 0 mm: 1 Inch: 2 (Default: 0)

**Pulse Rate (X axis: 401, Y axis: 801)**

Determines the amount of workpiece movement (with the selected unit) per pulse. For precision, the setting allows for 4 digits beyond the decimal point; however, the fourth digit may be rounded off when data is converted from millimeters.

Previously set parameters do not change their value when the pulse rate changes. Always reconfirm affected parameters when you change the pulse rate; as a general rule, always set the pulse rate first. Parameters defined under a former pulse rate will be ignored. A pulse rate setting of 0 (if the parameter are all cleared, for instance) will actually assign the default pulse rate of 1.0000.

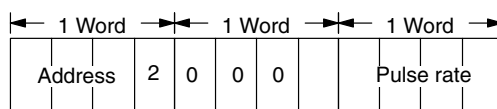

Setting range:  
0.0001 to 1.0000 unit/pulse  
(Default: 1.0000)

**Rotation Direction (X axis: 402, Y axis: 802)**

Relates to the position field sign bit. This parameter designates the control voltage as positive or negative. The position field sign establishes the position field as positive or negative.

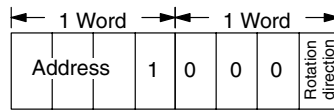

Positive voltage output for higher position: 0  
 Negative voltage output for higher position: 1

The following table shows the relationship between the sign designated for the positioning action, the rotation direction designated above, the motor driver voltage, and the direction of motor rotation.

Position field sign	Rotation direction	Direction of motor operation	Driver control voltage	Resulting rotation
Positive (in direction of increasing absolute positions)	Positive voltage (0)	CW	Positive	CW
		CCW	Positive	CCW
	Negative voltage (1)	CW	Negative	CW
		CCW	Negative	CCW
Negative (in direction of decreasing absolute positions)	Positive voltage (0)	CW	Positive	CW
		CCW	Positive	CCW
	Negative voltage (1)	CW	Negative	CW
		CCW	Negative	CCW

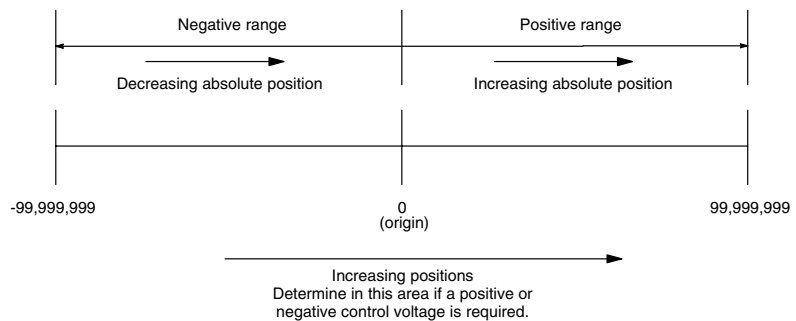

**Caution** Erroneous settings for this parameter can cause the servomotor system to run out of control. Change these settings immediately after turning on power when the motor is not engaged to a load.

**Encoder Type (X axis: 403,  
Y axis: 803)**

This parameter determines encoder characteristics.

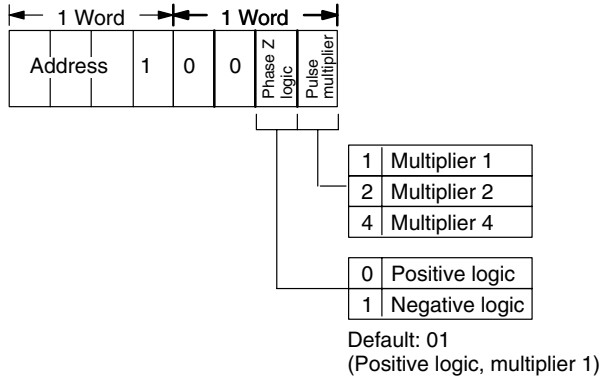

**Phase Z Logic**

Select positive logic (active high) or negative logic (active low) for the phase Z encoder. Positive logic phase Z (normally low) goes high at a signal; negative logic phase Z (normally high) goes low at a signal.

**Pulse Multiplier**

Select 1, 2, or 4 for the pulse multiplier depending on what type of phase-difference signals (Phases A and B) you require from the feedback pulses. Multiplier 1 sets the motor resolution equal to the encoder resolution. This means an encoder with a resolution of 1,000 pulses/revolution connected to a motor controls minimum motor rotation units in 1/1,000 revolution increments. With Multiplier 1 for example, for feedback pulses in the CW direction the figure below shows the generation of feedback pulses at the trailing edge of Phase A when Phase B is high.

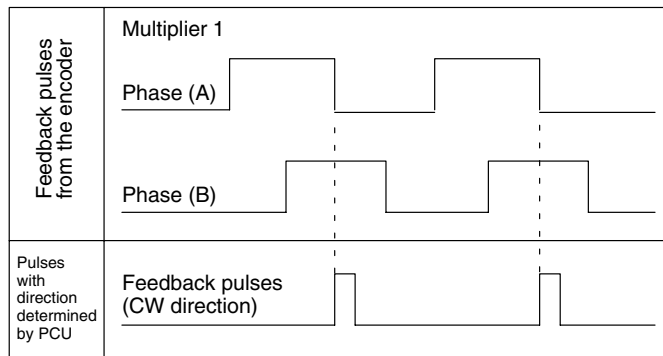

Multiplier 2 and Multiplier 4 provide double and quadruple resolutions of the encoder for the motor, respectively. If an encoder with a resolution of 1,000 pulses/revolution is connected to a motor, the encoder controls minimum motor rotation units in 1/2,000 revolution increments for Multiplier 2 and in 1/4,000 revolution increments for Multiplier 4. The respective precisions double and quadruple, but speeds drop respectively to 1/2 and 1/4.

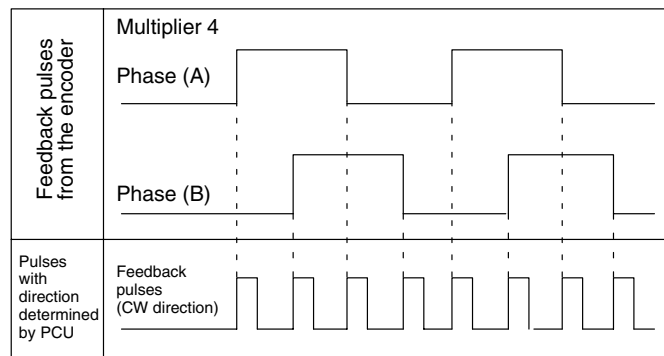
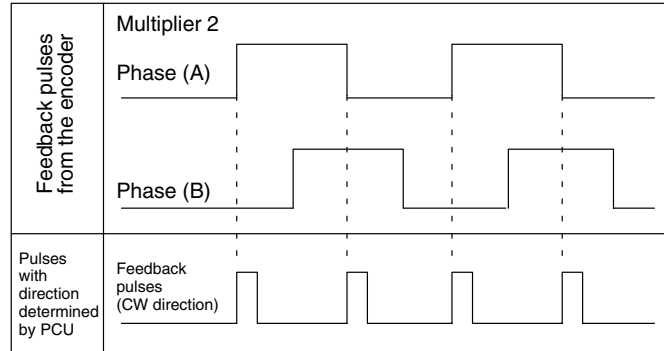

With Multiplier 2, feedback pulses are generated at the leading edge of Phase A when Phase B is low and at the trailing edge of Phase A when Phase B is high. With Multiplier 4, feedback pulses are generated in addition at the leading edge of Phase B when Phase A is high and at the trailing edge of Phase B when Phase A is low.

**Caution** Change the multiplier parameter immediately after power ON or origin search. Changing it at other times may cause the motor to move to its new “current position” at high speed based on the new multiplier.

**Gain and Error Counter Value Read (X axis: 404, Y axis: 804)**

Designates the voltage output per pulse. The servo system gain is normally adjusted with the variable resistor on the servomotor driver. This gain setting is used only as a supplement to the resistor adjustment.

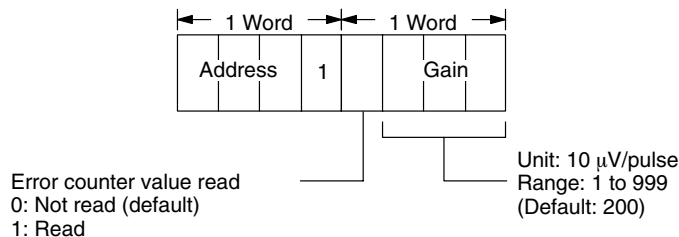

**Note** If the gain is too low, it will reduce the responsiveness of the motor and the motor will not be able to achieve the desired acceleration. If the gain is too high, vibration or other irregularities will result.

This parameter is used for reading the error counter value in the status area. Decide to read or not to read the error counter value when setting the gain set value.

If the parameter is set to error counter value read, the error counter value will be output to words 17 to 20 (the data read area) of the status area in 8-digit BCD. Words 17 to 18 will be used for single axis error counter value read.

Reading X- and Y-axis Error Counter Values:

Word	Bit																
	15	14	13	12	11	10	9	8	7	6	5	4	3	2	1	0	
17	X-axis sign				X-axis 10 <sup>6</sup>				X-axis 10 <sup>5</sup>				X-axis 10 <sup>4</sup>				} X axis
18	X-axis 10 <sup>3</sup>				X-axis 10 <sup>2</sup>				X-axis 10 <sup>1</sup>				X-axis 10 <sup>0</sup>				
19	Y-axis sign				Y-axis 10 <sup>6</sup>				Y-axis 10 <sup>5</sup>				Y-axis 10 <sup>4</sup>				} Y axis
20	Y-axis 10 <sup>3</sup>				Y-axis 10 <sup>2</sup>				Y-axis 10 <sup>1</sup>				Y-axis 10 <sup>0</sup>				
21	Top word of data read area																

The plus or minus sign will be displayed with 1 or 0 in bit 12.

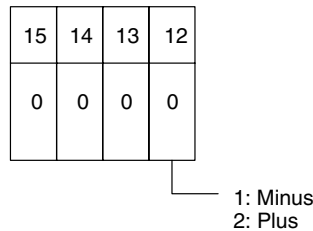

The top word of the data read area varies with the axis when reading the error counter value.

The top word of the data read area when reading the X- and Y-axis error counter values: 21

The top word of the data read area when reading the X- or Y-axis error counter value: 19

The top word of the data read area when not reading the X- or Y-axis error counter value: 17

**In-Position Zone (X axis: 405, Y axis: 805)**

Checks the error counter count of the servo system. When the count in the error counter reaches the value set here, the corresponding In Position flag turns ON and relays this condition externally. The flag remains ON as long as the count remains below the in-position zone. This flag will not turn ON while pulses are being input into the error counter regardless of the value of the counter.

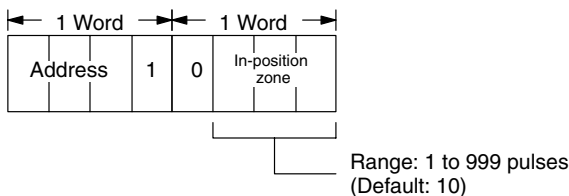

The following diagram and timing chart show the relationships between the error counter count, the in-position zone, the In-position Flag, and other positioning flags. As shown below, positioning is consider complete when the count in the error counter is less than or equal to the value set for the in-position zone.

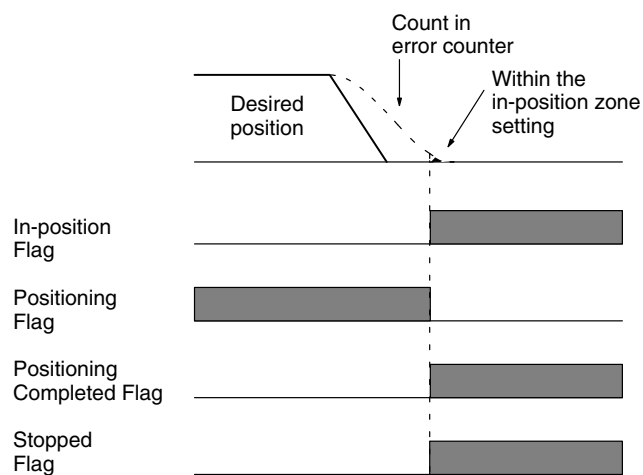
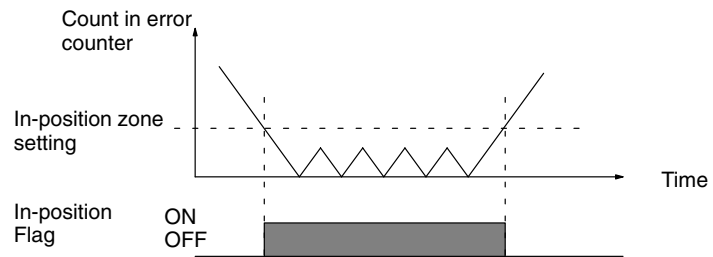

**Backlash Compensation (X axis: 406, Y axis: 806)**

Backlash refers to the amount of mechanical play present in gears. The meshing tolerance in the situation shown below would become a problem if the next positioning action were in the reverse direction. Generally, compensation is necessary whenever the direction changes.

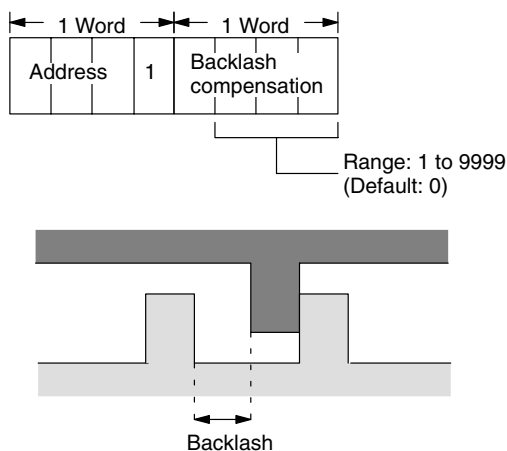

**Stroke Limit (+) (X axis: 407, Y axis: 807)**

Designates the limit in pulses for positive (+ area) positioning actions. A positioning action is positive or negative depending on the setting of the sign bit in the Attribute 1 field. To prevent overrunning of the motor, an error occurs when execution of positioning actions beyond the set value is attempted. This parameter occupies two words for a maximum 8-digit entry.

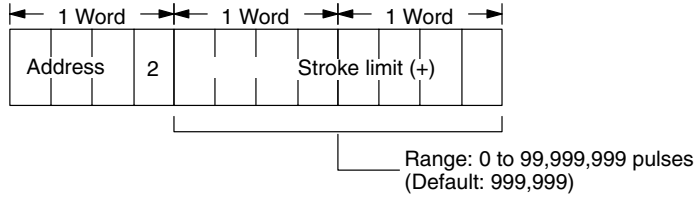

**! Caution** With both stroke limits at 0 (default settings), the stroke limits are not effective; i.e., motor overrun cannot be prevented with such settings. Furthermore, the stroke limit remains unchecked for JOG and pulse operations and for points passed during circular arc interpolation.

**Stroke Limit (-) (X axis: 408, Y axis: 808)**

Designates the limit in pulses for negative (- area) positioning actions. A positioning action is positive or negative depending on the setting of the sign bit in the Attribute 1 field. To prevent overrunning of the motor, an error occurs when execution of positioning actions beyond the set value is attempted. This parameter occupies 2 words for a maximum 8-digit entry.

**! Caution** With both stroke limits at 0 (default settings), the stroke limits are not effective; therefore, motor overrun cannot be prevented with such settings. Furthermore, the stroke limit remains unchecked for JOG and pulse operations and for points passed during circular arc interpolation.

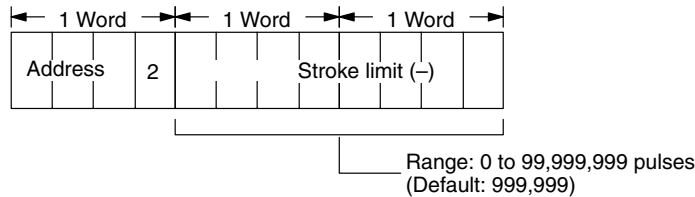

**Zone Setting (X axis: 409, Y axis: 809)**

Sets the acceleration zone and deceleration zone pulse counts. You can use these zones to check the amount of movement during acceleration and deceleration.

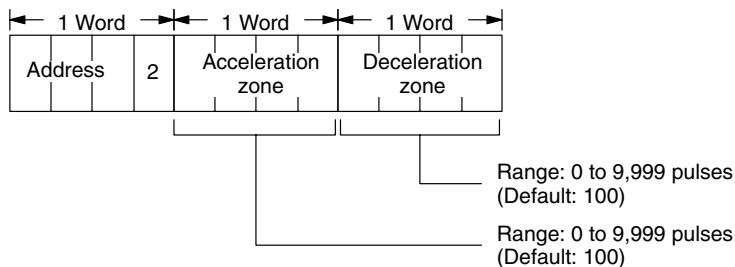

Set the acceleration zone in order to check the amount of movement from the positioning starting point. The Acceleration Zone flag remains ON while the positioning action executes the number of pulses set for the acceleration zone. Similarly the Deceleration Zone flag will stay ON while the positioning action executes the number of pulses in the deceleration zone. The Acceleration Zone and Deceleration Zone flags are OFF before and after the start and end positioning points. They are ON only during part of the positioning action. The zone setting parameter is invalid during circular arc interpolation. This parameter is effective for single-axis positioning and for straight-line interpolation only.

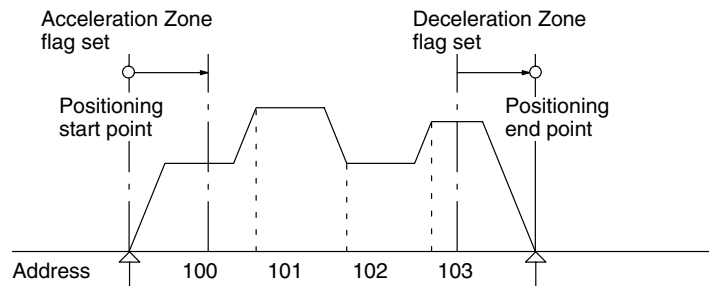
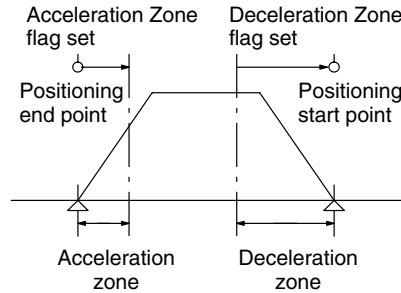

In a series of continuous positioning actions (completion codes = 1) the acceleration zone is effective for the first positioning action only; the deceleration zone, for the last positioning action only.

**Home Shift (X axis: 410, Y axis: 810)**

You can use home shift to add a designated number of pulses to any positioning action without affecting the origin. If HSFT (the home shift command) has been executed to enable home shift, the specified positioning action will shift positions by the amount of pulses set in this parameter. Refer to Section 7 Commands for details on HSFT.

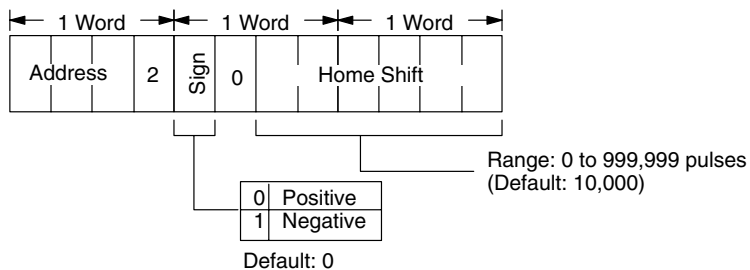



In the figure below for example, the parameter is set to shift positioning by 100 pulses. If the HSFT is enabled for positioning from P0 to P1 and to P2 (solid line), then positioning goes to (P1 + 100) and to (P2 + 100) (broken line). Home shift is not effective for absolute positions of 0, i.e., moves to the origin.

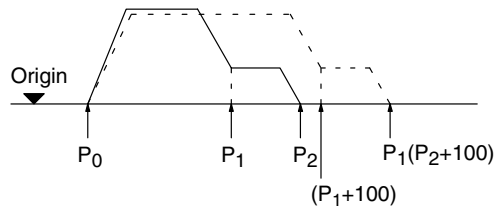

**Maximum Speed**  
(X axis: 411, Y axis: 811)

Defines the maximum speed used. You can set this parameter to prevent overrunning of the motor. The speed set here will be the maximum at which the motor will run, even if a command is executed with a dangerously high speed set by mistake. The acceleration and deceleration times also make use of this parameter.

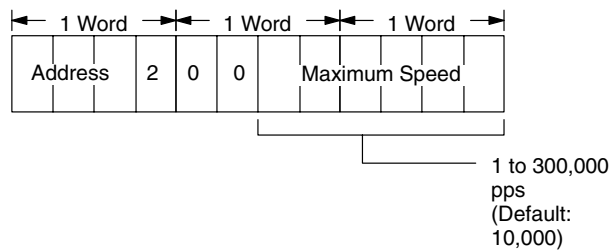

**Maximum Jogging Speed**  
(X axis: 412, Y axis: 812)

Defines the maximum JOG speed. You can set this parameter to prevent overrunning of the motor. The speed set here will be the maximum at which the motor will run during JOG, even if a command is executed with a dangerously high speed set by mistake.

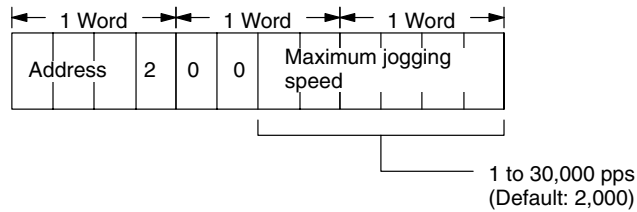

**Origin Search Direction** (X axis: 413, Y axis: 813)

Determines the final direction approach for an origin search. The positive direction means movement toward the positive (+) position field area. The negative direction means movement toward the negative (-) position field area. The position field sign is set in the Attribute 1 field of positioning actions. For more detail on establishing the origin, refer to Section 7.

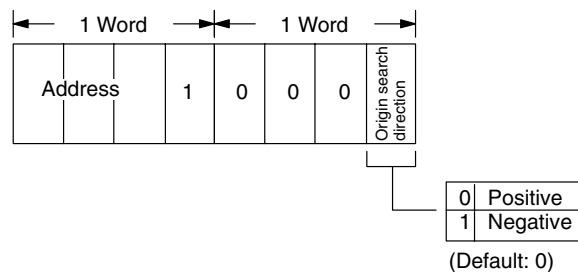

**Origin Compensation**  
(X axis: 414, Y axis: 814)

Corrects the mechanical origin detected via the phase Z origin search. There may be times when the mechanical origin which is detected may not be sufficiently precise. In such cases, you can use this parameter to add a designated number of pulses to the mechanical origin. The new point then becomes the origin. For more detail on establishing the origin, refer to *Section 7*.

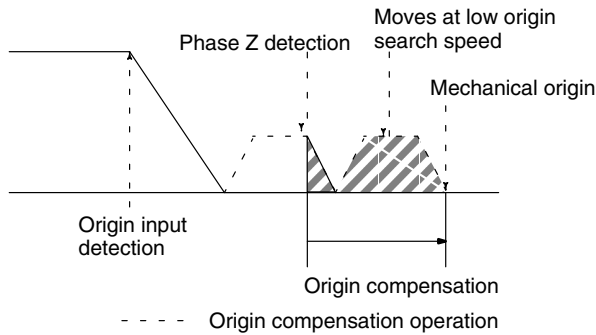
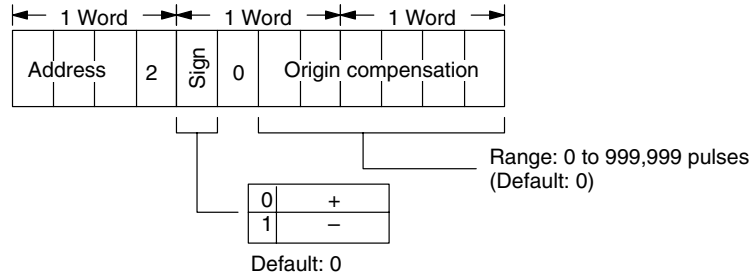

**High Origin Search Speed**  
(X axis: 415, Y axis: 815)

This speed is used in origin search until an origin input is detected. An origin search starts with this high speed and changes to the low speed with an origin input detection.

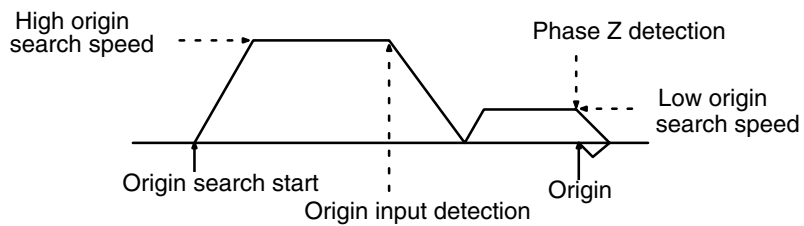
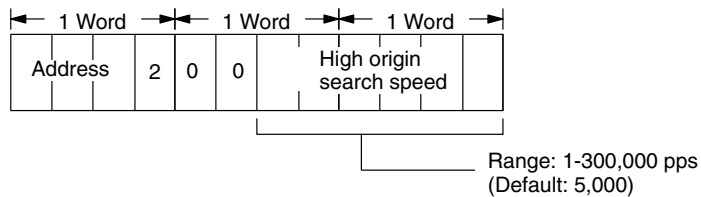

**Origin Search Acceleration and Deceleration (X axis: 416, Y axis 816)**

Sets the acceleration and deceleration times for origin search.

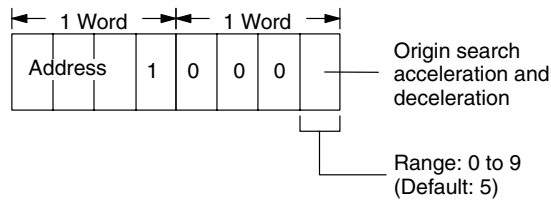

The times available are stored in addresses 460-469 for the X axis and 860-869 for the Y axis. Select the times by storing the last address digit here (e.g., 8 for time set at address 468). For setting acceleration and deceleration times, refer to *Section 3-6*.

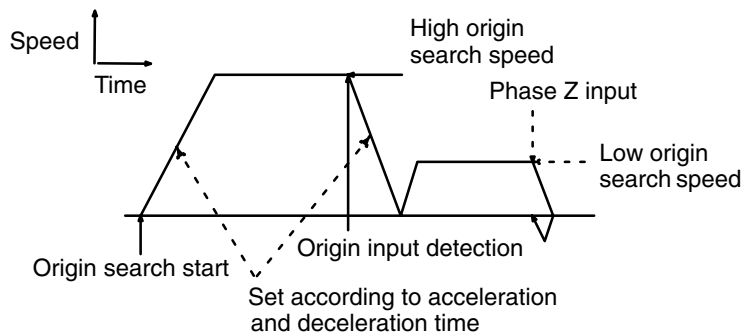

**Low Origin Search Speed (X axis: 417, Y axis: 817)**

This speed is used in origin search after an origin input is detected. An origin search starts with the high speed and changes to this low speed from the origin input detection until the first phase Z detection. See the previous figure under *High Origin Search Speed*.

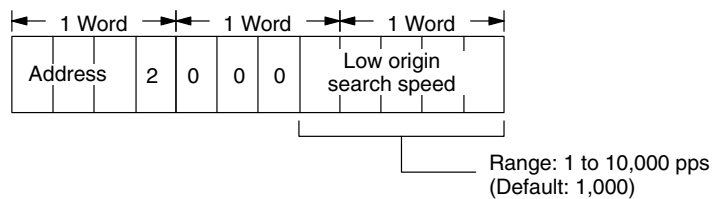

**Deceleration Stop (X axis: 418, Y axis: 818)**

The Deceleration Stop setting can be used to control how fast the positioning system will stop when an external interrupt is received during execution of JOG. The count in the error counter may, however, affect the stopping speed, as described below.

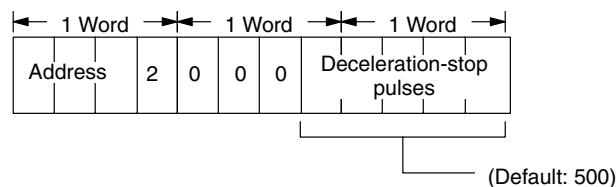

When the external interrupt input turns ON, the Deceleration Stop value is compared to the count in the error counter. If the count in the error counter is greater than the Deceleration Stop value, the Deceleration Stop value is not used and the system will stop after the positioning system has moved by the pulse count already in the error counter. This occurs when the jogging speed is high (creating a high count in the error counter) and the Deceleration Stop value is low.

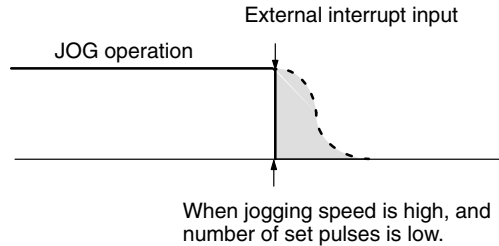

If the count in the error counter is less than the Deceleration Stop value, then the count in the error counter is increased to equal the Deceleration Stop value and the system will stop after the positioning system has moved by the number of pulses designated for the Deceleration Stop.

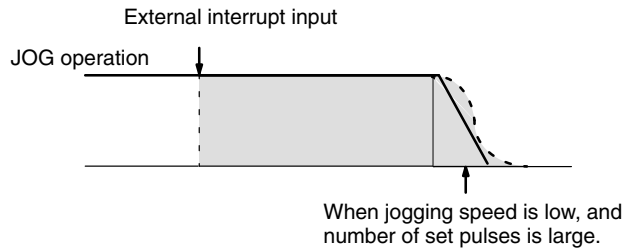

Therefore, if you want to stop as soon as possible for external interrupts, set the Deceleration Stop value low in comparison to the jogging speed. If you want to ensure that a specific distance is moved after receiving an external interrupt, set the Deceleration Stop value high in comparison to the jogging speed.

**Error Counter Capacity for Emergency Operation Stop (X axis: 419, Y axis: 819)**

This parameter is used to limit the error counter capacity while the emergency operation stop function of the Position Control Unit is active. Only while the emergency operation stop function is active, the error counter capacity will be set to the value that has been preset, in which case no accumulated value exceeding the measured value will be stored.

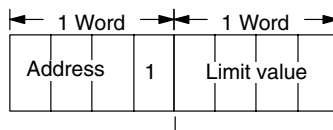

Range: 1 to 9,999 pulses (Default: 0)  
 If the value is set to 0, the error counter capacity will be set to 32,767.  
 If the value is changed to 1 to 9,999 from 0, the value cannot be reset to 0.

To move the object controlled by the Position Control Unit manually, for example, use this function so that the servo free function will be active while the emergency stop input is ON to move the object by hand and then disable the servo free function, in which case the object will not move quickly to return to the previous position.

**External Output Control  
(X axis: 420, Y axis: 820)**

This parameter is used to set the error counter capacity and external output control.

When the error counter overflows, external output 1 (OUT1) will be left as it is or turned OFF by setting external output 1 value to 1 or 0.

When the servo free function is active, external output 2 (OUT2) will be turned ON or OFF by setting external output 2 value to 1 or 0.

When the error counter overflows, the error counter overflow status will be turned ON.

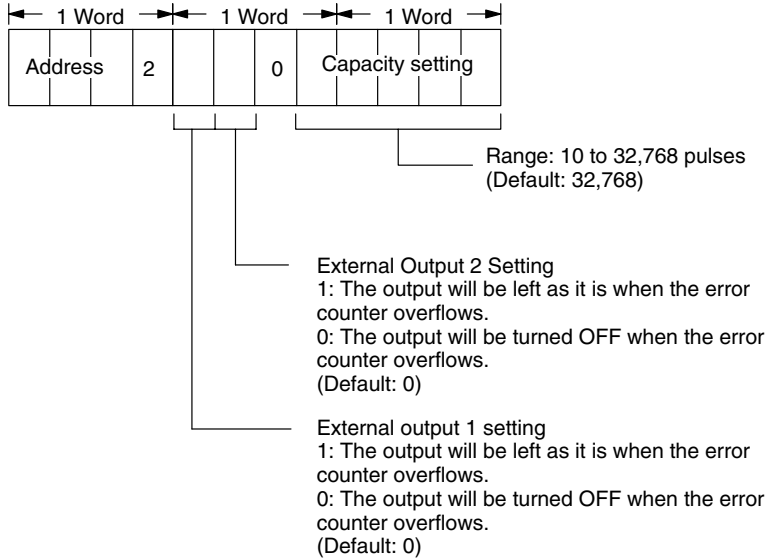

### 3-4 Setting Positioning Actions

Write in the data for positioning actions last, after making all of the other settings. Parameter settings are described in the previous subsections; dwell time, acceleration and deceleration, and speed settings are described in the following subsections. You can store up to 300 positioning actions for each axis in the EEPROM.

As shown in the following figure, each positioning action requires five words and consists of eight fields: address, position, speed, M code, dwell time, acceleration and deceleration time, attribute 1, and attribute 2.

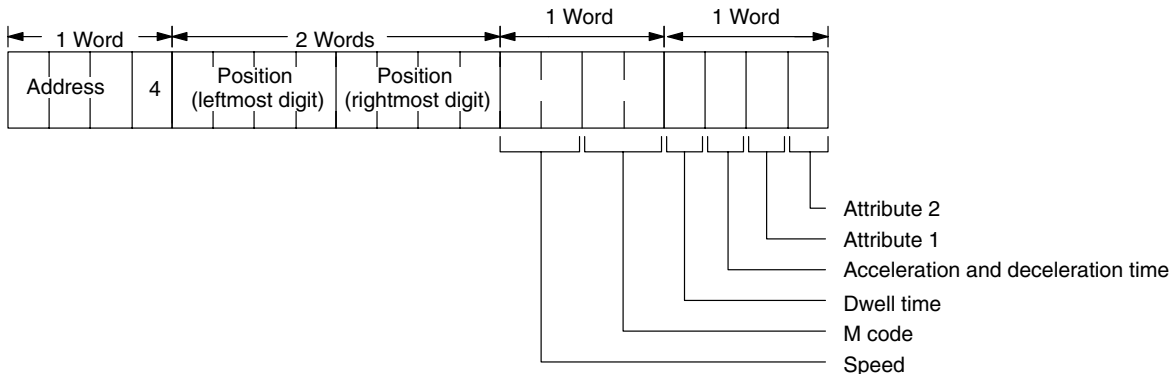

**Address Field**

The first of the five words for each position action is used to store its address. There are addresses from 100-399 for the X axis and 500-799 for the Y axis for up to 300 possible positioning actions for each axis.

<b>Position Field</b>	Positions for positioning actions are set using eight digits and may be between -99,999,999 and +99,999,999 pulses. Out of the eight digits, the leftmost four digits are held in one word and the rightmost eight digits are held in another word. These words only hold the numeric value of the position; the sign of the position is held in attribute 1 field. If the position field is zero, the M code and dwell time are still valid.
<b>Speed Field</b>	In this field you designate the speed for the move to the designated position. You can designate any of the 100 speeds(900-999) which you previously entered as speeds. (For setting speeds, see <i>Section 3-7</i> ). This field occupies 1/2 of a word. The range 00-99 designates speed addresses 900-999. A setting of 12, for example, executes positioning at the speed registered at address 912.
<b>M Code Field</b>	The M code (machine code) field occupies the other half of the fourth word. You use this field to directly register an M code (00 to 99) for each positioning action. The M code is a user-defined number that is passed to the PC for use in ladder programming. You can use it, for example, to set various code numbers for various positions so that when the workpiece passes particular positions the PC will respond with appropriate actions. The M code is valid when the positioning action has been completed.
<b>Dwell Time Field</b>	In this field you designates a dwell time for the positioning action. You may designate any of the 10 dwell times previously entered (addresses 450-459 for the X axis and 850-859 for the Y axis). For setting dwell times, see <i>Section 3-5</i> . This field occupies 1/4 of a word. The range 0-9 designates dwell time addresses 450-459 for the X axis. For example, a setting of 5 for an X-axis positioning action executes positioning with the dwell time registered at address 455.
<b>Acceleration and Deceleration Time Field</b>	In this field you designate the acceleration and deceleration time to the desired position. You can designate any of the 10 times previously entered (addresses 460-469 for the X axis and 860-869). For setting speeds, see <i>Section 3-7</i> . This field occupies 1/4 of a word. For example, a setting of 7 for an X-axis positioning action executes positioning at the acceleration and deceleration times registered at address 467. The acceleration/deceleration time is not used for circular arc interpolation; i.e., the designated speed is reached immediately.

**Attribute 1 Field**

You use this field to designate the interpolation code, position type (INC/ABS), and position field sign (+/-).

Attribute 1 field

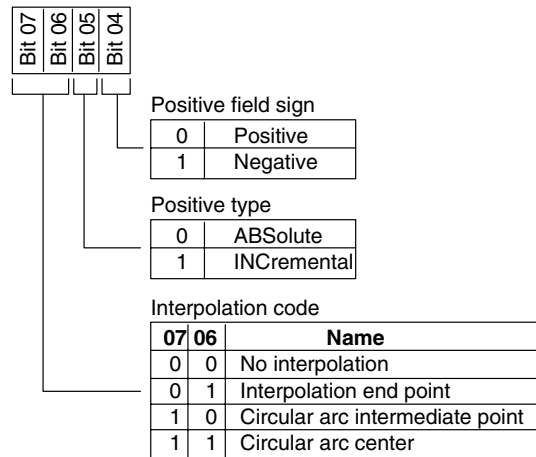

**Interpolation Code (Bits 07 and 06)**

The interpolation code bits determine whether a positioning action uses interpolating or not, and define what interpolating point the positioning action employs.

**Position Type (INC/ABS, Bit 05)**

The position type bit designates the positioning action as absolute (set to 0) or incremental (set to 1). An absolute position designates the position from the origin. An incremental position designates a position relative to the current position. Incremental positions are subject to a cumulative rounding error if the selected unit is millimeter or inch.

**Position Field Sign (+/-, Bit 04)**

Finally, the position field sign divides the position field range centered at the origin from -99,999,999 pulses to +99,999,999 pulses. Setting the rotation direction parameter to 0 permits a positive voltage output for the speed voltage when the position increases. Setting the rotation direction parameter to 1 permits a negative voltage output for the speed voltage when the position increases.

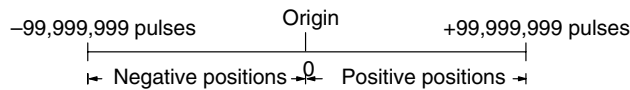

**Attribute 2 Field**

The attribute 2 field designates the completion code, circular arc interpolation direction, and positioning action enable/disable status.

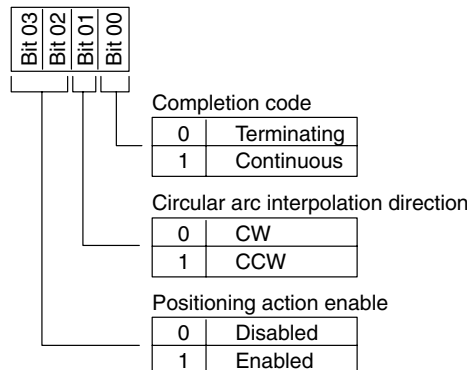

**Completion Codes**

The completion code determines whether a certain positioning action is part of a series or whether it terminates a series. Setting bit 00 to 0 designates a positioning action as terminating as shown below.

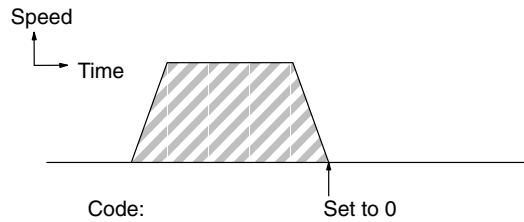

Setting bit 00 to 1 designates the positioning action as continuous as shown below.

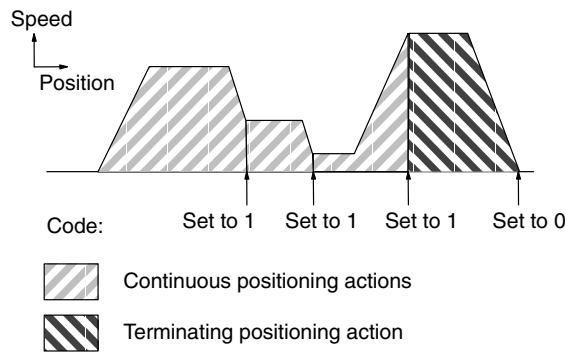

A completion code set to 1, however, differs slightly from the meaning in other Position Control Units. Here, positioning actions include the change in speed (acceleration or deceleration) for the next positioning action, instead of the change in speed for the current positioning action. The first positioning action in a series also includes the acceleration time needed to reach the first speed.

Always set the completion codes for the last positioning actions (addresses 399 and 799) to 0.

**Speed Changes in Previous Positioning Action**

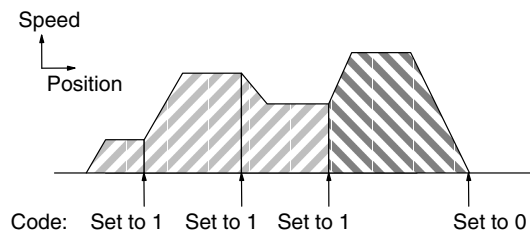

**Speed Changes in Current Positioning Action**

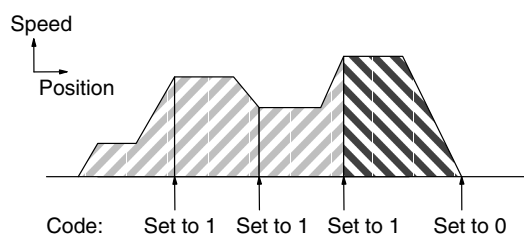



**Circular Arc Interpolation Direction**

This bit establishes the direction of interpolation when the circular arc center and circular arc end point are defined.

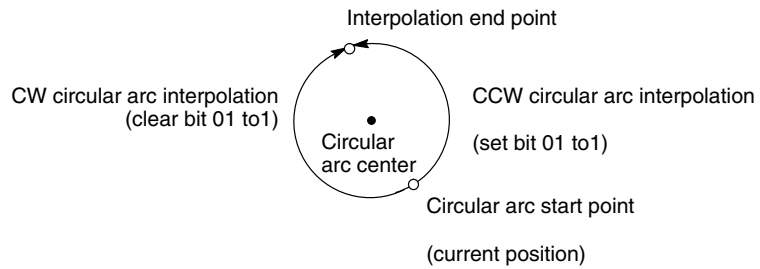

**Positioning Action Enable**

The positioning action enable bit (bit 02) determines whether a positioning action is enabled or disabled. (Bit 03 is not used.) When positioning actions are all enabled, they will be executed in sequence. When a positioning action is disabled, it will be skipped, although its completion code will still be effective (see below).

**Disabled Actions and Completion Codes**

Execution of disabled positioning actions depends on their completion codes. If the completion code of the disabled action is 0 (terminating), then no positioning will take place and the address counter will be incremented. If the completion code of the disabled action is 1 (continuous), the next positioning action will be executed according to its parameters. Naturally, if the next positioning action is also disabled, operation will then be based on the completion code for it. In simple terms, the completion codes of all positioning actions are effective, even if the positioning action is disabled and no positioning is carried out for it.

The following examples illustrates the relationship between disabled positioning actions and completion codes. The pertinent parameters for the positioning actions is as follows:

Address	Parameters
101	Incremental position, completion code of 1, enabled
102	Incremental position, completion code of 0, disabled
103	Incremental position, completion code of 0, enabled

If execution was started from address 101, the following action would result and the address counter would end up being set to 103.

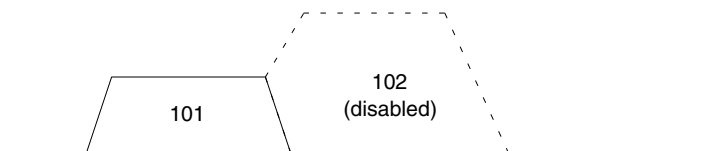

If the positioning action at address 102 had a completion code of 1, the following action would result.

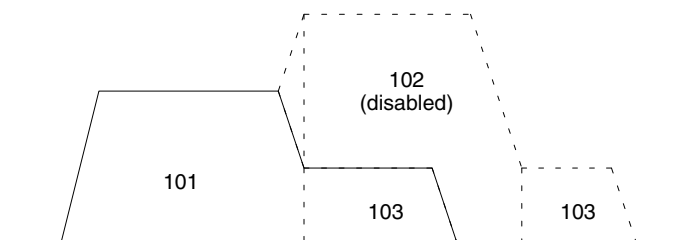

If the positioning action at address 103 was to an absolute position rather than an incremental one, the following action would result.

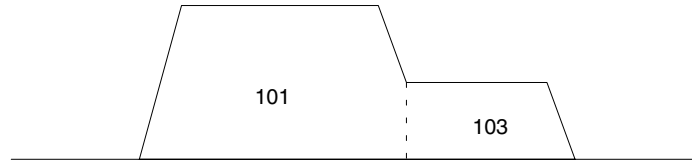

As you can see, enabling/disabling various positioning actions can be used to achieve a wide range of positioning without requiring changes in the ladder program.

The following example also shows how to control positioning without changing the ladder diagram by enabling/disabling positioning actions.

If we set up a ladder diagram program to execute three positioning actions at addresses 101, 102, and 103, the following positioning movements could be achieved by enabling/disabling different actions. In all cases, the next address to be executed would be 104. It is assumed that all actions have a completion code of 0.

If all three positioning actions were enabled, the following movements would take place.

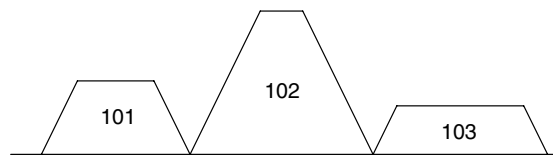

If only the positioning actions at 101 and 103 were enabled, the following movements would take place.

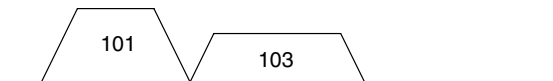

If only the positioning action at 102 was enabled, the following movements would take place.

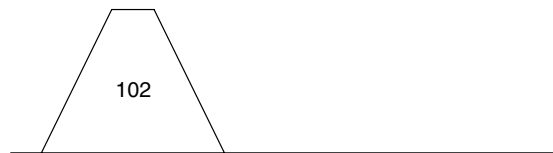

### 3-5 Setting Dwell Times

In servomotor positioning, hunting can occur near the positioning destination because of gain. Sudden deceleration and high-speed movement over a short distance aggravate the tendency to hunt. To minimize the effects of hunting, positioning completed signals can be held for a certain duration or dwell time before they are set. You can enter one of 10 dwell times at addresses 450-459 for the X axis and 850-859 for the Y axis. Positioning actions call these times as abbreviated addresses. The dwell time allows positioning to complete before another positioning action begins. For a comprehensive listing of default values see *3-8 Initial Data*.

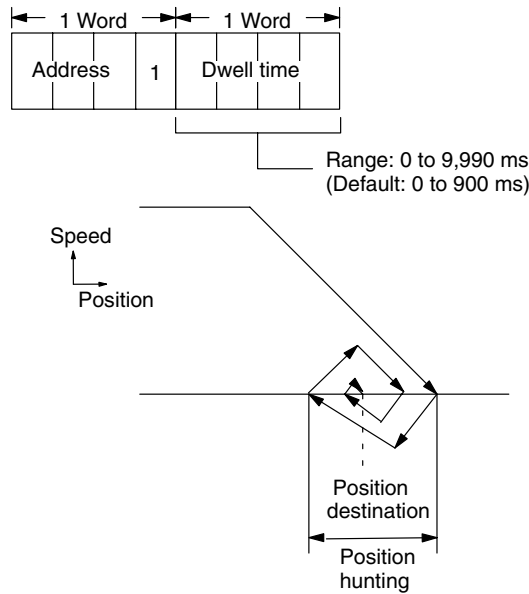

### 3-6 Setting Acceleration and Deceleration Times

The acceleration and deceleration times are stored in addresses 460-469 for the X axis and 869-869 for the Y axis. The values in the addresses set the time it takes to accelerate to maximum speed (addresses 411, 811) from a stop and decelerate from maximum speed to a stop. Positioning actions also call these times as abbreviated addresses. You can set one of 10 acceleration and 10 deceleration times (each address stores acceleration and deceleration times in separate words). Select the times appropriately for your needs by computing proportionally for acceleration to the operating speed needed. For a comprehensive list of default values see *3-8 Initial Data*.

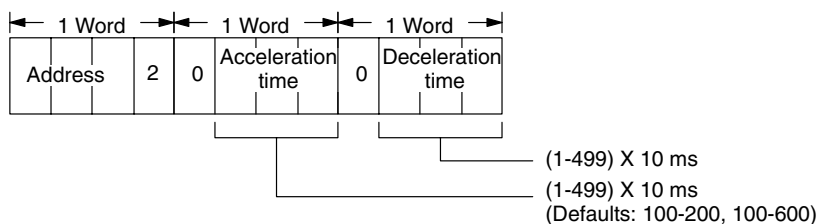

Acceleration time to operating speed = Acceleration time x (Target speed)/(Maximum speed)

Deceleration time to operating speed = Deceleration time x (Target speed)/(Maximum speed)

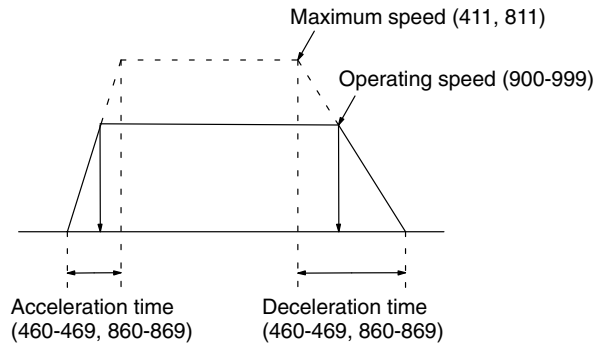

Acceleration and deceleration times are effective for the following operations only: Positioning actions; Deceleration-stop commands (XSTP, YSTP, ISTOP) from the PC or Teaching Box (deceleration only); JOG commands (XJOG, YJOG, IJOG) (acceleration only); Origin search commands (XORG, YORG, IORG); Pauses (XHLD, YHLD, IHLD) (deceleration only); and Pause releases (XREL, YREL, IREL) (acceleration only).

### 3-7 Setting Speeds

Speeds are allocated three words each, one for the address and two for up to 6 BCD digits. Speeds occupy addresses 900 through 999 for both axes. Up to 100 speeds needed in your application may be entered for positioning and jogging. Positioning actions and the JOG commands call these speeds. For a comprehensive listing of default values see 3-8 Initial Data.

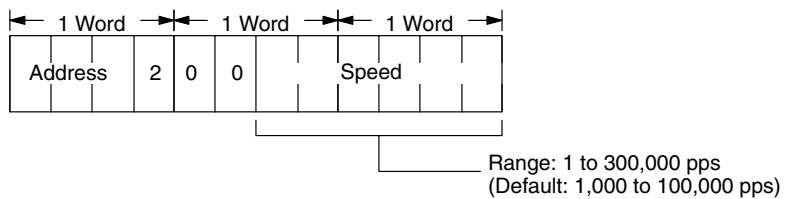

## 3-8 Initial Data

The following tables list the default data loaded originally in the EEPROM at the factory. The operation of each of these is described in *Section 3 Data Configuration*. This data will be automatically loaded to RAM whenever power is turned on. The contents of EEPROM can be changed with the Write EEPROM (STORE) command.

### X-Axis Positioning Actions

Address	Description	Setting	Attributes
100	X-axis test data (1)	Position = 500 pulses, speed = 1 kpps, M code = 01	Dwell time = 500 ms Absolute, terminating, acceleration time = 200 ms deceleration time = 200 ms
101	X-axis test data (2)	Position = -500 pulse, speed = 3kpps, M code = 02	Dwell time = 0 ms Incremental, continuous, acceleration time = 100 ms deceleration time = 100 ms
102	X-axis test data (2)	Position = -500 pulses, speed = 2 kpps, M code = 03	Dwell time = 500 ms Absolute, continuous, acceleration time = 100 ms deceleration time = 300 ms
103	X-axis test data (2)	Position = -500 pulses, speed = 1 kpps, M code = 04	Dwell time = 0 ms Absolute, terminating, acceleration time = 100 ms deceleration time = 200 ms
104	X- and Y-axes test data (1)	Position = 0 pulse, speed = 1 kpps, M code = 05	Dwell time = 100 ms Absolute, interpolating end, acceleration time = 100 ms deceleration time = 200ms

## X-Axis Parameters

Address	Description	Setting	Attributes
400	Unit	0	Pulse
401	Pulse rate	1	1 unit/pulse
402	Rotation direction	0	Positive voltage output with incremental positioning actions
403	Encoder type	01	Single multiplier, positive logic
404	Gain	200	2,000 $\mu$ V/pulse
405	In-position zone	10	pulses
406	Backlash compensation	0	None
407	Stroke limit (+)	999,999	pulses
408	Stroke limit (-)	999,999	pulses
409	Zone settings	01000100	Accel. zone 100 pulses Accel. zone 100 pulses
410	Home shift	0	pulses
411	Maximum speed	10,000	pps
412	Maximum jogging speed	2,000	pps
413	Origin search direction	0	Direction of positive voltage output
414	Origin compensation	0	pulses
415	High origin search speed	5,000	pps
416	Origin search acceleration and deceleration	5	Acceleration time =200ms Deceleration time =200ms
417	Low origin search speed	1,000	pps
418	Deceleration-stop	500	pulses

**Dwell Times (X and Y Axes)**

Address	Description	Setting	Attributes
450/850	Dwell time #0	0	ms
451/851	Dwell time #1	100	ms
452/852	Dwell time #2	200	ms
453/853	Dwell time #3	300	ms
454/854	Dwell time #4	400	ms
455/855	Dwell time #5	500	ms
456/856	Dwell time #6	600	ms
457/857	Dwell time #7	700	ms
458/858	Dwell time #8	800	ms
459/859	Dwell time #9	900	ms

**Acceleration and Deceleration Times (X and Y Axes)**

Address	Description	Setting	Attributes
460/860	Accel./ Decel. time #0	00100010	Acceleration time = 100 ms Deceleration time = 100 ms
461/861	Accel./ Decel. time #1	00100020	Acceleration time = 100 ms Deceleration time = 200 ms
462/862	Accel./ Decel. time #2	00100030	Acceleration time = 100 ms Deceleration time = 300 ms
463/863	Accel./ Decel. time #3	00100040	Acceleration time = 100 ms Deceleration time = 400 ms
464/864	Accel./ Decel. time #4	00100050	Acceleration time = 100 ms Deceleration time = 500 ms
465/865	Accel./ Decel. time #5	00200020	Acceleration time = 200 ms Deceleration time = 200 ms
466/866	Accel./ Decel. time #6	00200030	Acceleration time = 200 ms Deceleration time = 300 ms
467/867	Accel./ Decel. time #7	00200040	Acceleration time = 200 ms Deceleration time = 400 ms
468/868	Accel./ Decel. time #8	00200050	Acceleration time = 200 ms Deceleration time = 500 ms
469/869	Accel./ Decel. time #9	00200060	Acceleration time = 200 ms Deceleration time = 600 ms

## Y-Axis Positioning Actions

Address	Description	Setting	Attributes
500	Y-axis test data (1)	Position = 500 pulses, speed = 1 kpps, M code = 06	Dwell time = 500 ms Incremental, terminating, acceleration = 200 ms deceleration = 200 ms
501	Y-axis test data (2)	Position = 0 pulses, speed = 1 kpps, M code = 07	Dwell time = 0 ms Absolute, continuous, acceleration = 100 ms deceleration = 100 ms
502	Y-axis test data (2)	Position = -500 pulses, speed = 2 kpps, M code = 08	Dwell time = 500 ms Incremental, continuous, acceleration = 100 ms deceleration = 300 ms
503	Y-axis test data (2)	Position = -1,000 pulses, speed = 3 kpps, M code = 09	Dwell time = 0 ms Absolute, terminating, acceleration = 100 ms deceleration = 200ms
504	X- and Y-axes test data (1)	Position = 0 pulses, speed = 1 kpps, M code = 10	Dwell time = 100 ms Absolute, interpolating end, acceleration = 100 ms deceleration = 200 ms



## Y-Axis Parameters

Address	Description	Setting	Attributes
800	Unit	0	Pulse
801	Pulse rate	1	1 unit/pulse
802	Rotation direction	0	Positive voltage output with incremental positioning actions
803	Encoder type	01	Single multiplier, positive logic
804	Gain	200	2,000 $\mu$ V/pulse
805	In-position zone	10	10 pulses
806	Backlash compensation	0	None
807	Stroke limit (+)	999,999	pulses
808	Stroke limit (-)	999,999	pulses
809	Zone settings	01000100	Accel. Zone 100 pulses Decel. zone 100 pulses
810	Home shift	0	pulses
811	Maximum speed	10,000	pps
812	Maximum jogging speed	2,000	pps
813	Origin search speed	0	Direction of positive voltage voltage output
814	Origin compensation	0	pulses
815	High origin search speed	5,000	pps
816	Origin search acceleration and deceleration	5	Acceleration time = 200 ms Deceleration time = 200 ms
817	Low origin search speed	1,000	pps
818	Deceleration-stop	500	pulses

**Speeds**

<b>Address</b>	<b>Description</b>	<b>Setting</b>	<b>Attributes</b>
900	Speed #0	10,000	pps
901	Speed #1	1,000	pps
902	Speed #2	2,000	pps
903	Speed #3	3,000	pps
904	Speed #4	4,000	pps
905	Speed #5	5,000	pps
906	Speed #6	6,000	pps
907	Speed #7	7,000	pps
908	Speed #8	8,000	pps
909	Speed #9	9,000	pps

# SECTION 4

## Data Communication with PC

4-1	Compatible Models and Words .....	58
4-2	PC Programs .....	59
4-2-1	Basic Command Transmission Program (PC to Position Control Unit) .....	60
4-2-2	Basic Status Flag Reception Program (Position Control Unit to PC) .....	60
4-2-3	Transferring and Saving Data .....	62

## 4-1 Compatible Models and Words

Both data and commands can be transferred between the Position Control Unit (PCU) and Programmable Controller (PC) through the use of Intelligent I/O Read and Write instructions executed by the PC.

### Compatible Models

The Intelligent I/O Read instruction READ(88) and Intelligent I/O Write instruction WRIT(87) control PCU-PC communication. The CPU must be able to use these two instructions. Use of the NC222-E is thus possible with the following PCs only.

- C500 (with CPU model C500-CPU11-EV1 only)
- C1000H (with any CPU)
- C2000H (with any CPU)

**Note** The NC222-E must be mounted either to a CPU Rack or Expansion I/O Rack to operate. Communications via READ(88) and WRIT(87) will not be possible if it is mounted to a Slave Rack.

### IR Area Allocations

Two I/O words are allocated for the Position Control Unit for communication with the PC.

Word	Bit	Name	Description
n (OUT)	00	(PC Busy)	Used in WRIT(87) / READ(88) instruction.
	01	(PC Writing)	
	02	(PC Read Completed)	
	03	–	Used within the PCU, and not available to the user.
	15	–	
n+1 (IN)	00	(PCU Busy)	Used in WRIT(87) / READ(88) instruction.
	01	(Reading PCU)	
	02	(PCU Write Completed)	
	03	–	Used within the PCU, and not available to the user.
	15	–	

- Note**
1. The input and output words allocated to the Position Control Unit must not be used by any instruction other than WRIT(87) or READ(88). Do not use MOV(21) or OUT with these words.
  2. The mode of the PC has no effect on the operation of the NC222-E, i.e., the NC222-E will continue to operate regardless of the PC mode.
  3. Commands and/or data can be sent to the NC222-E from either the PC (i.e., the program) or the Teaching Box. If a transmission is attempted from both at the same time, the transmission that arrives first will be given priority.

## 4-2 PC Programs

The PC program maintains two data flow directions.

- PC to Position Control Unit (PCU) command and parameter transmission uses the Intelligent I/O Write instruction WRIT(87). Commands and parameters are differentiated by address inside the PCU.
- Position Control Unit to PC status reception uses the Intelligent I/O Read instruction READ(88).

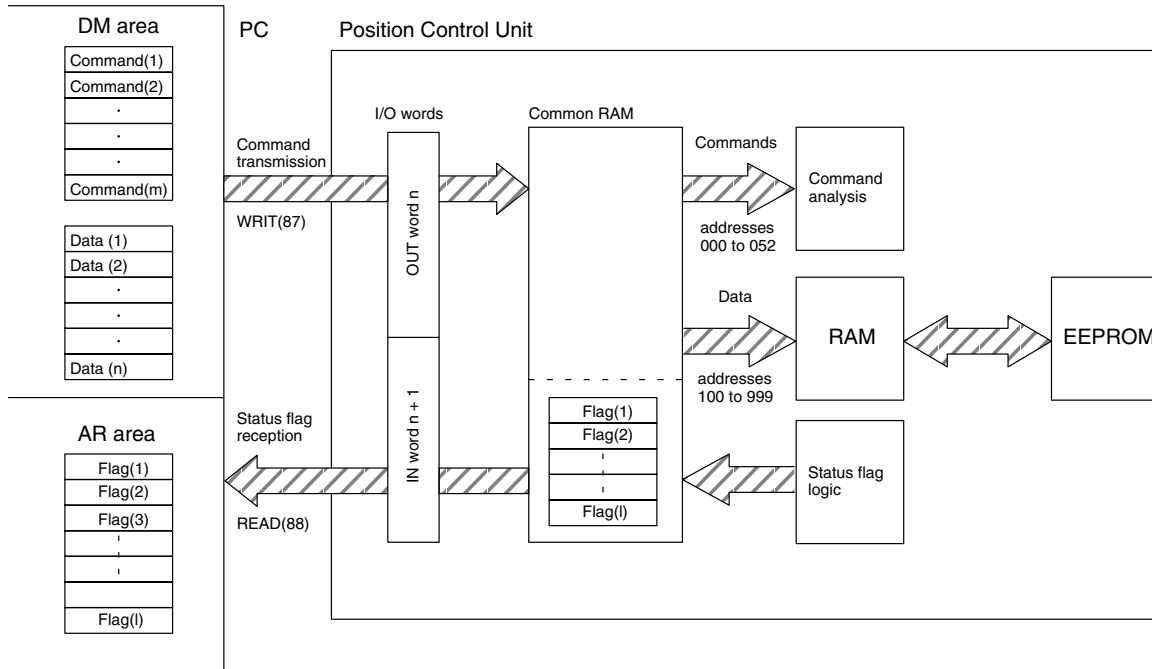

- One or more commands stored in the DM area of the PC are transmitted in a stream to the Position Control Unit, where they are executed sequentially. The Position Control Unit functions according to the commands sent.
- Data (parameters) stored in the DM area are transmitted to the PCU and stored in RAM. Commands can then be used to transfer RAM contents to EEPROM.
- For status flag reception, flag allocations are determined by the Position Control Unit; therefore, the same status flags are transferred to the AR area each time the Intelligent I/O Read instruction is executed.
- Because command transmission and status reception rely on the Intelligent I/O Read and Write instructions, a standard PC program can be developed. The use of such a standard program is strongly recommended.

### 4-2-1 Basic Command Transmission Program (PC to Position Control Unit)

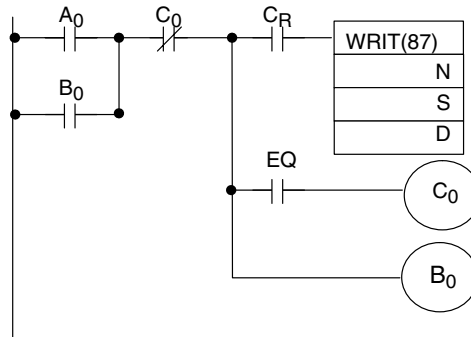

- A<sub>0</sub>: Start input (differentiated input)
- B<sub>0</sub>: Status-holding work bit
- C<sub>0</sub>: Transmission completed work bit
- C<sub>R</sub>: Command Ready (bit 15 of first word ON when READ (85) is executed)
- N<sub>0</sub>: Differentiation no.
- N: Transferred word count
- S: Transfer source start word
- D: I/O word for transfer destination (word n occupied by the PCU)
- EQ: Equals flag

### 4-2-2 Basic Status Flag Reception Program (Position Control Unit to PC)

Status flag reception should be written at the end of the PC program.

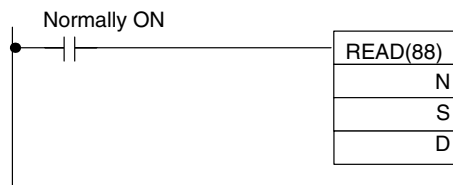

- N: Transfer word count (17 words minimum)
- S: Transfer source I/O word (word n + 1 occupied by the PCU)
- D: Transfer destination start word (see *Section 5-2 Status Word Allocation*)

Refer to your PC's *Operation Manual* for further details on the Intelligent I/O Read and Write Instructions.

**Status Reception Problems** The RAM in the PCU that contains status data is accessed both by the PCU to write the status and by the PC to read status (READ(88)). Both of these operation cannot take place at the same time.

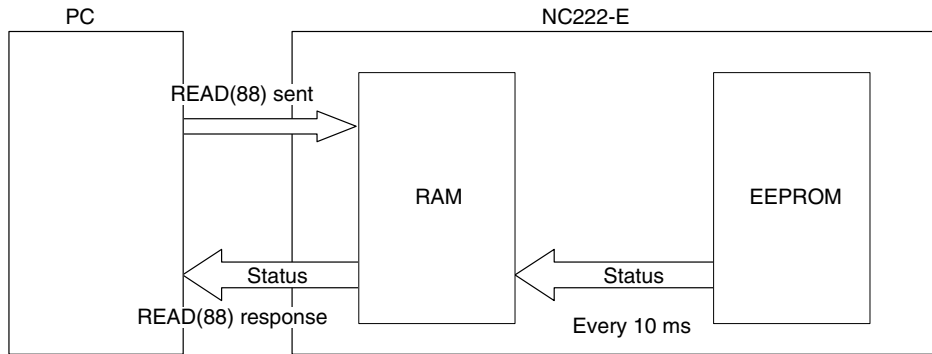

If a READ(88) is attempted while the PCU is writing status, READ(88) will be ignored. The status write operation is performed approximately every 10 ms and requires approximately 1 ms to complete, i.e., there is up to about a 1 in 10 chance that READ(88) will not be executed as programmed. This situation is illustrated below.

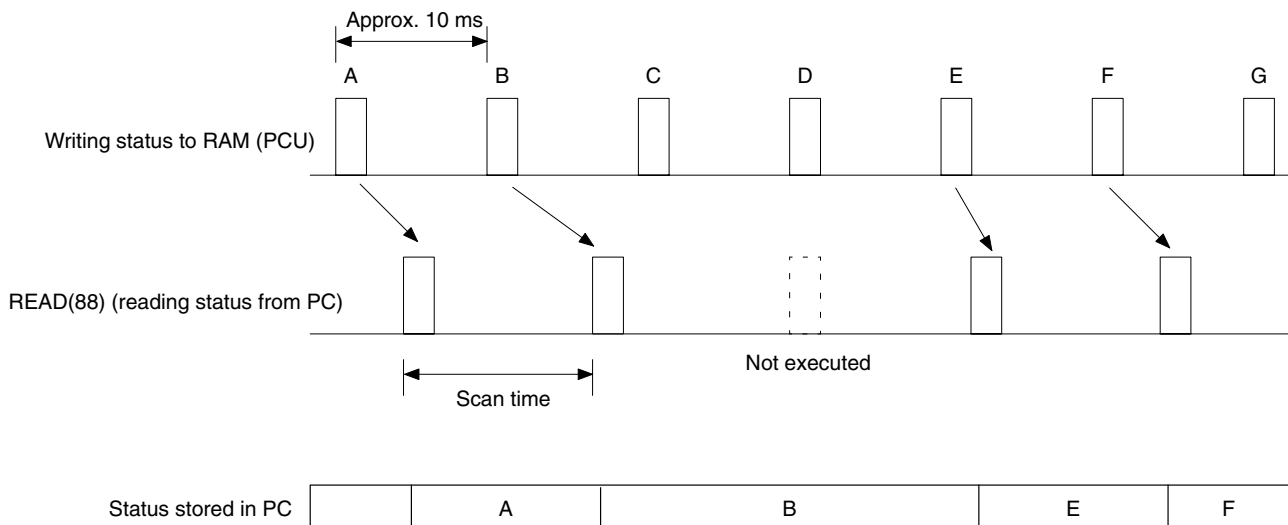

If it is necessary to ensure that status is read during each program scan, block programming can be used. One example of how to do this is shown below. This example reads out 17 status words to IR 100 to IR 116 for a PCU allocated IR 000 and IR 001. The loop in the block program will be taken until the Equals Flag (=) turns ON (i.e., until IR 1200 turns ON).

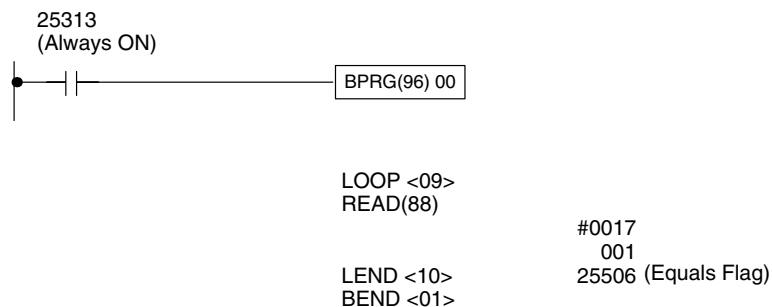

**Note** READ(88) can be executed for the NC222 PCU only once each time the status is updated in the PCU (i.e., each time PCU internal status is written to the shared RAM). If the scan time of the CPU Unit is shorter than the status update time of the PCU (approx. 10 ms), the above type of ladder programming can be used to extend the scan time of the CPU Unit to at least the status update time of the PCU.

**Start Time**

The time required for the Position Control Unit to output an instruction voltage after the Position Control Unit receives the start instruction varies with the combination of positioning data.

Pattern	Start time			
	Y-axis single start with X axis not in operation X-axis single start with Y axis not in operation	Y-axis single start with X axis in operation X-axis single start with Y axis in operation	Both axes start	Interpolation start
0	14 ms	16 ms	16 ms	22 ms
1 (Number of consecutive data $\cong$ 2)	16 ms	17 ms	19 ms	26 ms
1 (Number of consecutive data $\cong$ 3)	17 ms	19 ms	21 ms	30 ms

### 4-2-3 Transferring and Saving Data

**Data Transfers**

Parameters and positioning actions stored in the DM area can be transferred to RAM in the PCU using a program like the one shown below. Be sure the first DM word contains an addresses and that no more than 127 words are transferred at once. If it is necessary to transfer more words, repeat the program section. When repeating the transfer, always used the work bit turned on by the Equals Flag (=) in the first transfer (IR 5002 in the following example) to activate the second transfer.

When transferring data, addresses need not be consecutive. If they are not consecutive, each address will need to be specified individually. If they are consecutive, only the first address need be designated (see transfer of Y-axis data in 8-2 Data Transmission Program).

**Data Transmission Example**

The following program can be used to transfer data written in the DM area of the PC to the NC222-E. When transferring data, it is important that the first word designate the address and that data for the required number of words is set properly.

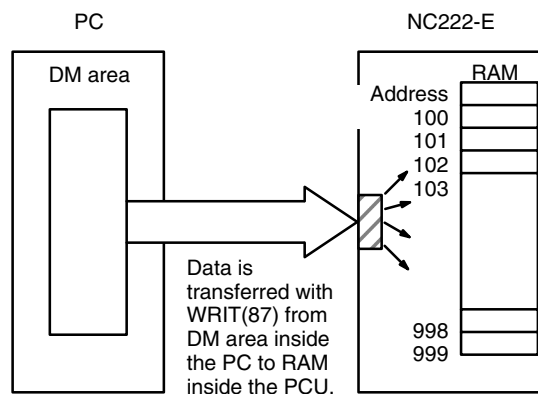



Up to 127 words can be transferred each time WRIT(87) is executed. When it is necessary to transfer more words, the Equals Flag should be used to activate further transmissions with WRIT(87), as shown below.

When data is transferred into the NC222-E, data is automatically stored in RAM according to the addresses given. If the addresses of the data being transferred are consecutive, it is only necessary to designate the address of the first one. An example of this is given in 8-2 Data Transmission Program.

The data prepared for transfer and the program used are shown below.

**Note** Data cannot be transferred while the NC222-E is positioning, i.e., while one or more axes are moving.

**Data**

DM 1000	4 1 1 2	Maximum speed (X)
DM 1001	0 0 0 5	Address: 411
DM 1002	0 0 0 0	
DM 1003	4 1 3 1	Origin search direction (X)
DM 1004	0 0 0 1	Address: 413
DM 1005	4 5 0 1	Dwell time 0 (X)
DM 1006	0 0 1 0	Address: 450
DM 1007	4 6 6 2	Acceleration pattern 6 (X)
DM 1008	0 0 3 0	Address: 466
DM 1009	0 0 4 0	
DM 1010	2 0 0 4	Positioning action 100 (X)
DM 1011	0 0 0 2	Address: 200
DM 1012	5 0 0 0	
DM 1013	0 0 1 0	
DM 1014	0 6 4 4	
DM 1015	9 0 0 2	Speed 0 (X, Y)
DM 1016	0 0 0 0	Address: 900
DM 1017	1 0 0 0	
DM 1018	8 0 4 2	Gain (Y)
DM 1019	0 0 2 0	Address: 804
DM 1020	8 0 5 2	In-position zone (Y)
DM 1021	0 0 2 0	Address: 805
DM 1022	6 0 0 4	Positioning action 100 (Y)
DM 1023	0 0 0 1	Address: 600
DM 1024	0 0 0 0	
DM 1025	0 0 1 0	
DM 1026	0 6 4 4	

Program

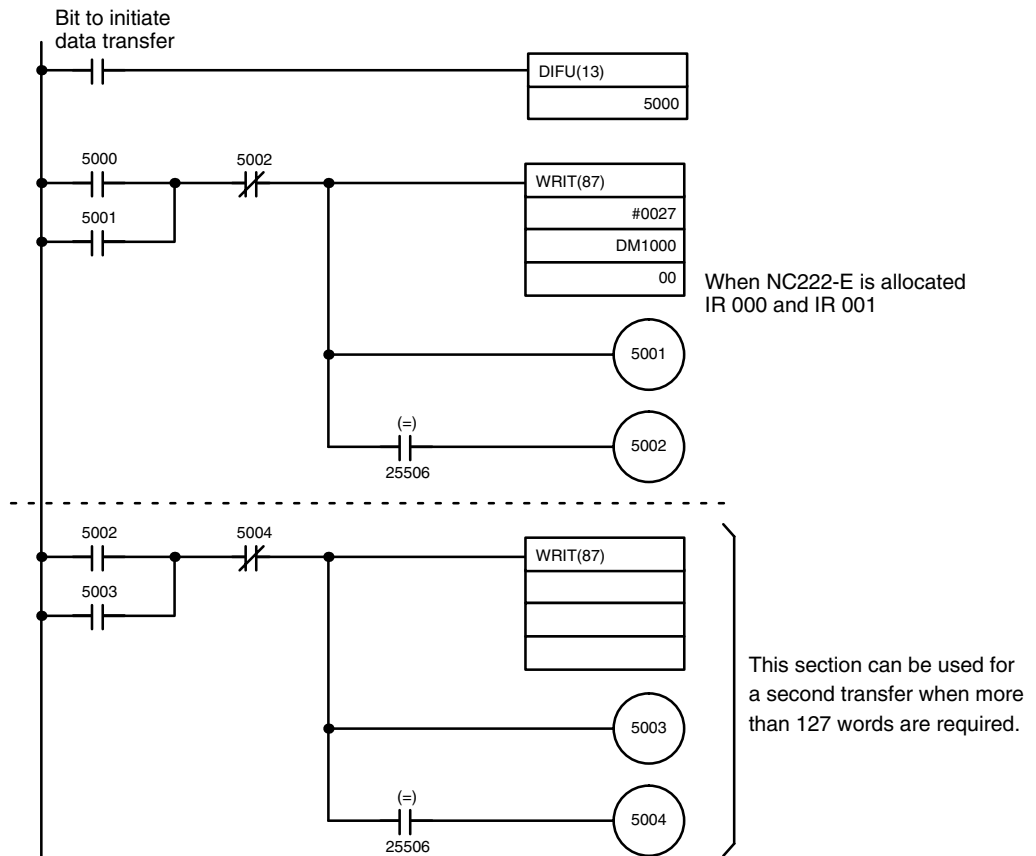

Storing RAM Data

PCU operation is based on the parameters and positioning actions contained in RAM. When power is turned on, the data in EEPROM is read into RAM. The data in RAM can then be changed by transferring data with WRIT(87) or from the Teaching Box. This data will be deleted and replaced by EEPROM data the next time power is turned off and back on. There is a command available, however, to write RAM data to EEPROM (STORE), as well as one to restore EEPROM data to RAM (RESTR). These commands can be used along with WRIT(88) (or the Teaching Box) to control the data in RAM. This situation is illustrated below.

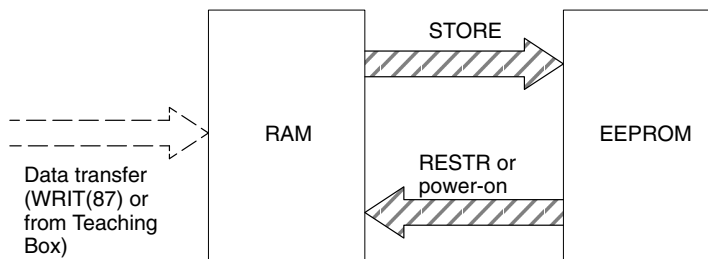

Refer to 6-2 Command Descriptions for details on STORE and RESTR.

**Note** STORE should not be executed more than 5,000 times.

# SECTION 5

## Operating Status

This section describes the status information available from the PCU. This information is read into the PC by executing the Intelligent I/O Read instruction, READ(88). Also explained in this section is the relationship between certain PCU commands and the status information.

5-1	Flag Transitions and Types .....	66
5-2	Status Word Allocations .....	68
5-3	Status Word Details .....	70
	5-3-1 System Flags .....	70
	5-3-2 Error Code and System Error Flags .....	71
	5-3-3 Error Op Codes .....	72
	5-3-4 Status Flags (1) .....	72
	5-3-5 Status Flags (2) .....	73
	5-3-6 Current Position .....	75
	5-3-7 M Code .....	76
	5-3-8 Multiplier and Current Positioning Action Address .....	76
	5-3-9 Current Speed Address and Override Coefficient .....	77
5-4	Flag Changes .....	77

## 5-1 Flag Transitions and Types

### Relationship between Flags and Commands

Flags and other status information will change as commands are executed. These changes are illustrated in the following illustration. When the commands along the arrow are executed, the flags given at the ends of the arrows turn ON. See the command allocations table at the beginning of *Section 6* for command code definitions.

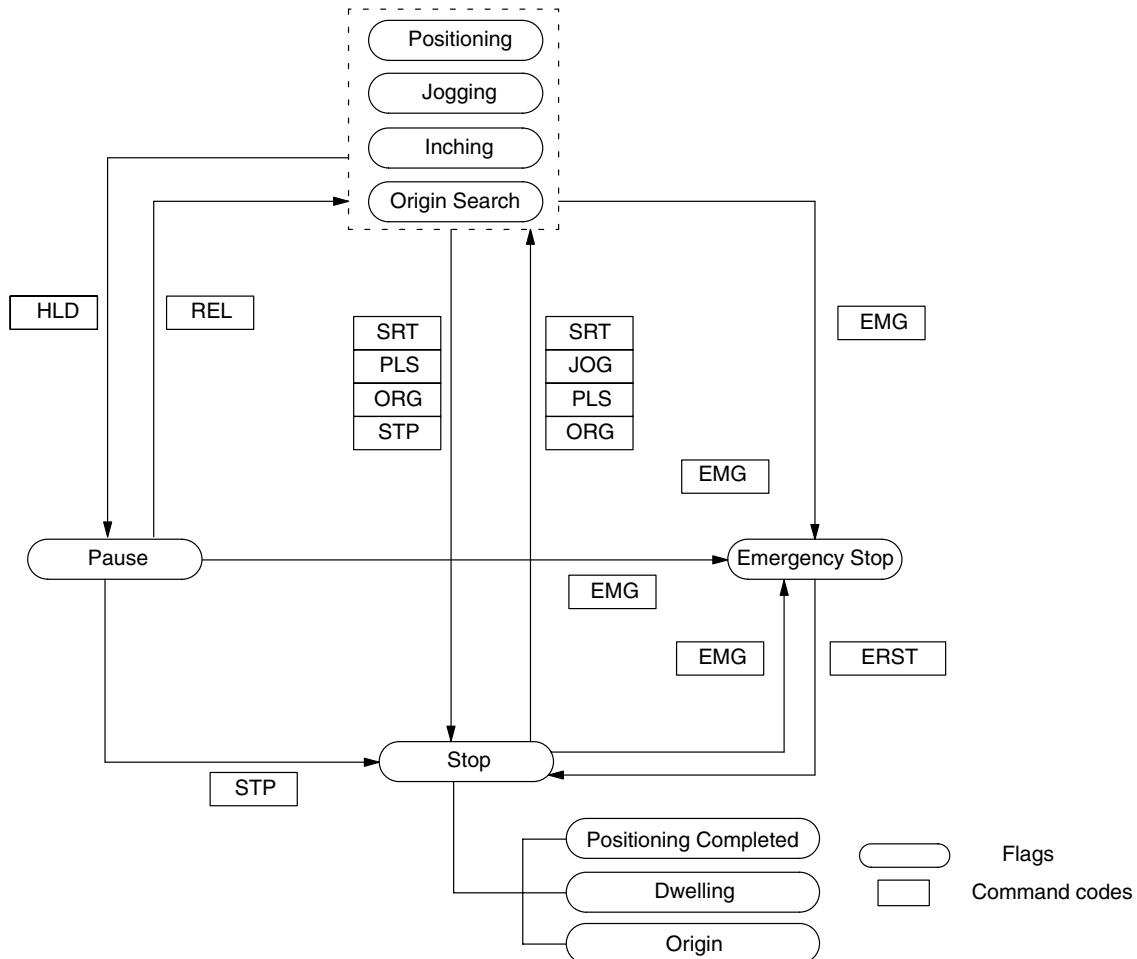

### IR Area Flags

Flags are assigned to the IN I/O word.

Wd	Word n+1
Bit	IN
00	(PCU Busy)*
01	(PCU Reading)*
02	(PCU Writing Completed)*
⋮	Not used by the user
15	

\*These bits are used by READ(88) and WRIT(87) and are not designed to be accessed by the user.

**Types of Flags**

The Intelligent I/O Read instruction READ(88) is used to read blocks of flags and status data into a memory area in the PC. Their contents are as follows:

System status flags
Error codes
System error status flags
Error codes
Status flags
Current position
M code
Multiplier data
Current positioning action address
Current speed address
Override coefficient
Read data

## 5-2 Status Word Allocations

The PC uses the Intelligent I/O Read instruction READ(88) to read status from the Position Control Unit. Refer to the end of 4-2 PC Programs for the READ(88) format. Data word allocations are summarized as follows:

Wd		Bit																
		b15	b14	b13	b12	b11	b10	b9	b8	b7	b6	b5	b4	b3	b2	b1	b0	
X-Y common area	D + 0	Command Ready	PCU Ready	Teaching Box Ready	Teaching Box Connected	External Display Connected	/	/	PC Communications Disabled	Interpolating Circular Arc	Interpolating Straight Line	Reading EE-PROM	Writing EE-PROM	EE-PROM Write Completed	Speeds Cleared	Data read completion	/	
	System status flags																	
	D + 1	Hardware Error	Communications Error	Y-axis System Error	X-axis System Error	System/data Processing Error	Interpolating Error	Y-axis Command Error	X-axis Command Error									
	Error code and system error status flags																	
X-axis area	D + 2	Error-related OP code (leftmost digit)				Error-related OP code (middle digit)				Error-related OP code (rightmost digit)				Number of error-related OP codes				
	Error codes																	
	D + 3	Parameters Enabled	Origin Set	Parameters Cleared	Positioning Data Cleared	Home Shift	Override	Dwelling	Positioning Completed	Origin search	Inching	Jogging	Positioning	Stop	Pause	Emergency Stop	Current Position Sign	
Status flags (1)																		
D + 4	CW Movement	CCW Movement	Accelerating	Constant Speed	Decelerating	In Position	Acceleration Zone	Deceleration Zone	Origin	OUT2 Output	OUT1 Output	CWLS Input	CCWLS Input	External Interrupt	External Emergency Stop	Origin Input		
Status flags (2)																		
D + 5	BCD (10 <sup>7</sup> digit)				BCD (10 <sup>6</sup> digit)				BCD (10 <sup>5</sup> digit)				BCD (10 <sup>4</sup> digit)					
Current position (leftmost digits)																		
D + 6	BCD (10 <sup>3</sup> digit)				BCD (10 <sup>2</sup> digit)				BCD (10 <sup>1</sup> digit)				BCD (10 <sup>0</sup> digit)					
Current position (rightmost digits)																		
D + 7	/	/	/	/	/	/	/	/										
M code																		
D + 8	Multiplier: 1, 2, 4				Current positioning action address (10 <sup>2</sup> digit)				Current positioning action address (10 <sup>1</sup> digit)				Current positioning action address (10 <sup>0</sup> digit)					
Multiplier/Current positioning action address																		
D + 9	Current speed address (10 <sup>1</sup> digit)				Current speed address (10 <sup>0</sup> digit)				Override coefficient (10 <sup>1</sup> digit)				Override coefficient (10 <sup>0</sup> digit)					
Current speed address/Override coefficient																		

Wd	Bit																
	b15	b14	b13	b12	b11	b10	b9	b8	b7	b6	b5	b4	b3	b2	b1	b0	
Y-axis area	D + 10	Parameters Enabled	Origin Set	Parameters Cleared	Positioning Data Cleared	Home Shift	Override	Dwelling	Positioning Completed	Origin search	Inching	Jogging	Positioning	Stop	Pause	Emergency Stop	Current Position Sign
	Status flags (1)																
	D + 11	CW Movement	CCW Movement	Accelerating	Constant Speed	Decelerating	In Position	Acceleration Zone	Deceleration Zone	Origin	OUT2 Output	OUT1 Output	CWLS Input	CCWLS Input	External Interrupt	External Emergency Stop	Origin Input
	Status flags (2)																
	D + 12	BCD (10 <sup>7</sup> digit)				BCD (10 <sup>6</sup> digit)				BCD (10 <sup>5</sup> digit)				BCD (10 <sup>4</sup> digit)			
	Current position (leftmost digits)																
	D + 13	BCD (10 <sup>3</sup> digit)				BCD (10 <sup>2</sup> digit)				BCD (10 <sup>1</sup> digit)				BCD (10 <sup>0</sup> digit)			
	Current position (rightmost digits)																
	D + 14	Unused				M code (10 <sup>1</sup> digit)				M code (10 <sup>0</sup> digit)							
	M code																
	D + 15	Multiplier: 1, 2, 4				Current positioning action address (10 <sup>2</sup> digit)				Current positioning action address (10 <sup>1</sup> digit)				Current positioning action address (10 <sup>0</sup> digit)			
	Multiplier/Current positioning action address																
D + 16	Current speed address (10 <sup>1</sup> digit)				Current speed address (10 <sup>0</sup> digit)				Override coefficient (10 <sup>1</sup> digit)				Override coefficient (10 <sup>0</sup> digit)				
Current speed address/Override coefficient																	
X-Y common area	D + 17	Read Data Area															
	?																
	D + 126	Read Data Area															

- Note**
1. When a READ(88) is executed, data values are placed in the Read Data Area. There are 110 words (17-126) set aside for this use.
  2. During interpolation, the X-axis attributes and parameters are used for all shaded parameters above.

## 5-3 Status Word Details

### 5-3-1 System Flags

Word D + 0

Bit	Function	Content	ON	OFF	Initially	On error
0	–	Unused	–	–	–	–
1	Data read completion	Indicates that data has been read in the data read area with the data read command (READ 045).	Turns ON from OFF or OFF from ON whenever data is read in the data read area.		0	No change
2	Speeds Cleared	Indicates all speeds cleared.	When CLR (clear) is processed to set all speeds to 0.	When one or more speeds is not 0.	0 or 1	No change
3	EEPROM Write Completed	Indicates EEPROM has been written normally.	When STORE (write to EEPROM command) is completed.	When STORE (EEPROM write command) is received.	0	No change
4	Writing EEPROM	Indicates data is being written to EEPROM.	When STORE is being processed.	When STORE is completed.	0	No change
5	Reading EEPROM	Indicates data is being read from EEPROM.	When RESTR (read from EEPROM command) is being processed.	When RESTR has been processed.	0	No change
6	Interpolating Straight Line	Indicates straight line interpolation.	When processing straight line interpolation.	When processing other than straight line interpolation.	0	0
7	Interpolating Circular Arc	Indicates circular arc interpolation.	When processing circular arc interpolation	When processing other than circular arc interpolation.	0	0
8	PC Communications Disabled	Ignores commands from PC except emergency stops and the error reset.	When disable command is received from Teaching Box.	When disable command is cancelled from Teaching Box.	0	No change
9	–	Unused	–	–	0	0
10	–	Unused	–	–	0	0
11	External Display Connected	Indicates whether the External Display is connected.	When external display connection is confirmed.	When external display disconnection is confirmed.	0 or 1	No change
12	Teaching Box Connected	Indicates whether the Teaching Box is connected.	When Teaching Box connection is confirmed.	When Teaching Box disconnection is confirmed.	0 or 1	No change
13	Teaching Box Ready	Indicates whether Teaching box is operable.	When Teaching Box is operable.	When Teaching Box is inoperable.	0 to 1	No change
14	PCU Ready	Indicates whether PCU hardware is operable.	When PCU internal initialization is completed.	During initialization or when initialization fails.	0 to 1	No change
15	Command Ready	Indicates the PCU is operable.	When command inputs are enabled.	While commands are being interpreted.	0 to 1	No change



### 5-3-2 Error Code and System Error Flags

Refer to *Appendix D* for error codes.

Word D + 1

Bit	Function	Content	ON	OFF	Initially	On system error
0	Error Code	Code in BCD (10 <sup>0</sup> digit) indicating cause of error.	When either a system error, communication error, or command error occurs.	If system error or communication error, when reset command is received. If command error, when a valid command is received.	0 0	Corresponding error code
1						
2						
3						
4		Code in BCD (10 <sup>1</sup> digit) indicating cause of error.				
5						
6						
7						
8	X-Axis Command Error	Indicates command error affecting X-axis.	When error code of 30, 31, 32, 33, 40, or 41 is generated for a servo control command.	When proper command is received.	0	No change
9	Y-Axis Command Error	Indicates command error affecting Y-axis.	When error code of 30, 31, 32, 33, 40, or 41 is generated for a servo control command.	When proper command is received.	0	No change
10	Interpolation Error	Indicates command error affecting interpolation.	When error code of 50 to 53 is generated for a Start command.	When proper command is received.	0	No change
11	System / Data Processing Error	Indicates command error affecting system or data processing.	When error code of 54 to 58, 40, or 41 is generated for a system or data processing command.	When proper command is received.	0	No change
12	X-Axis System Error	Indicates system error affecting X-axis.	When error code of 10, 12, or 20 is generated.	When ERST (error reset) is processed.	0 or 1	1
13	Y-Axis System Error	Indicates system error affecting Y-axis.	When error code of 11, 13, or 21 is generated.	When ERST (error reset) is processed.	0 or 1	1
14	Communications Error	Indicates communications error with Teaching Box or External Display.	When error code of 70 to 72 is generated.	When ERST (error reset) is processed.	0 or 1	No change
15	Hardware Error	Indicates internal malfunction.	When error code of 00 to 02 is generated.	When ERST (error reset) is processed. Reset will not be possible for error codes of 01 or 02.	0 or 1	No change

### 5-3-3 Error Op Codes

Word D + 2

Bit	Function	Content	ON	OFF	Initially	On error
0	Error Op Codes	Displays number of operands in BCD of preceding Op code.	When a command error has occurred.	When a proper command has been received.	0	0
1						
2						
3						
4		Displays error-causing Op code rightmost digit in BCD.				
5						
6						
7		Displays error-causing Op code middle digit in BCD.				
8						
9						
10		Displays error-causing Op code leftmost digit in BCD.				
11						
12						
13						
14						
15						

### 5-3-4 Status Flags (1)

Command abbreviations are listed below the table (also see the beginning of Section 7 Commands). “X,” “Y,” and “I” indicate the X axis, Y axis, and interpolation and precede some commands. These prefixes are mostly dropped in the table because the flags are the same for the three different servo control modes.

X-Axis: Word D + 3  
Y-Axis: Word D + 10

Bit	Function	Content	ON	OFF	Initially	On system error
0	Current Position Sign	Indicates current position as positive or negative.	When current position is negative (-).	When current position is zero (0) or positive (+), or when origin is not defined.	0	0
1	Emergency Stop	Indicates an emergency stop.	When EMG or external interrupt is received.	When ERST (error reset) is received.	0 or 1	1 or no change
2	Pause	Indicates pause.	When HLD is received.	When REL, STP, or EMG is received, when external interrupt is received, or when system error occurs.	0	0
3	Stop	Indicates positioning has stopped.	When there is no movement.	When SRT, JOG, ORG, or PLS is received.	1	1
4	Positioning	Indicates positioning.	When SRT is received.	When a terminating completion code is executed and positioning is completed, when a system error occurs, or when STP or external interrupt is completed.	0	0
5	Jogging	Indicates jogging.	When JOG is received.	When STP or external interrupt completed or system error occurs.	0	0

Bit	Function	Content	ON	OFF	Initially	On system error
6	Inching	Indicates inching.	When PLS is received.	When inching is completed, or a system error occurs.	0	0
7	Origin Search	Indicates origin search	When ORG is received.	When origin search or STP is completed, or when a system error occurs.	0	0
8	Positioning Completed	Indicates positioning has completed.	After positioning end and dwell time has expired.	When SRT is received or a system error occurs.	0	0
9	Dwelling	Indicates dwell time is active.	When positioning ends and dwell time starts.	When dwell time expires or emergency stop or system error occurs.	0	0
10	Override	Indicates override coefficient other than 1.0.	When override command received is other than 1.0.	When 1.0 override command is received.	0	No change
11	Home Shift	Indicates home shift status.	When home shift enable is received.	When home shift disable is received.	0	No change
12	Positioning Data Cleared	Indicates all positioning actions cleared.	When CLR clears all positioning data.	When at least one positioning action is registered.	0 or 1	No change
13	Parameters Cleared	Indicates parameters all cleared.	When CLR clears all parameters.	When at least one parameter is registered.	0 or 1	No change
14	Origin Set	Indicates establishment and existence of origin.	After ORG is completed, or when CCHG is received.	When a system error occurs.	0	0
15	Parameters Enabled	Indicates all parameters are within established range.	When parameters are within established ranges.	When one or more parameters are outside established ranges.	0 or 1	No change

**Command Codes**

Prefixes: X = X axis, Y = Y axis, I = interpolation.

Main codes: SRT = start, STP = deceleration-stop, JOG = jogging, PLS = inching, ORG = origin search, OVR = override, HLD = pause, REL = pause release, and EMG = emergency stop.

Non-prefixing codes: END = command end, NOP = no operation, ERST = error reset, OUT = external output control, ACLR = all clear, CLR = clear, BCLR = block clear, STORE = EEPROM write (data save), RESTR = EEPROM read, READ = data read, MOV = data transfer, TEACH = teaching, CCHG = change current position, and HSFT = home shift.

**5-3-5 Status Flags (2)**

X-Axis: Word D + 4  
Y-Axis: Word D + 11

Bit	Function	Content	ON	OFF	Initially	On system error
0	Origin Input	Indicates origin input status.	When origin input is ON.	When origin input is OFF.	0 or 1	No change
1	External Emergency Stop	Indicates external emergency stop status.	When external emergency stop input is ON (open).	When external emergency stop input is OFF.	0 or 1	No change

Bit	Function	Content	ON	OFF	Initially	On system error
2	External Interrupt	Indicates external interrupt status.	When external interrupt input is ON.	When external interrupt input is OFF.	0 or 1	No change
3	CCWLS Input	Indicates CCW limit switch status.	When CCWLS input is ON (open).	When CCWLS input is OFF	0 or 1	No change
4	CWLS Input	Indicates CW limit switch status.	When CWLS input is ON (open).	When CWLS input is OFF.	0 or 1	No change
5	OUT1 Output	Indicates OUT1 status.	When OUT1 output is ON.	When OUT1 output is OFF.	0	No change
6	OUT2 Output	Indicates OUT2 status.	When OUT2 output is ON.	When OUT2 output is OFF.	0	No change
7	Origin	Indicates positioning at origin.	When stopped at zero.	When origin is not defined, when moving, when stopped at any point other than the origin, or when a system error occurs.	0	0
8	Deceleration Zone	Indicates position is within deceleration zone.	When current position and positioning destination differ by less than the set value.	When positioning or EMG is completed, or when a system error occurs.	0	0
9	Acceleration Zone	Indicates position is within acceleration zone.	When SRT* or JOG is received.	When the starting position and current position differ by the set value, when STP is completed, or when a system error occurs.	0	0
10	In Position	Indicates the error counter status according to the set zone.	When error counter does not exceed in-position zone.	When error counter exceeds setting for in-position zone or when pulses are being input to counter.	0 or 1	No change
11	Decelerating	Indicates deceleration.	At the deceleration starting position.	When positioning action or STP ends.	0 or 1	0
12	Constant Speed	Indicates constant speed.	At acceleration end point.	At acceleration start point.	0	0
13	Accelerating	Indicates acceleration.	When SRT or JOG is received.	At constant speed point or deceleration point.	0	0
14	CCW Movement	Indicates CCW movement.	During CCW positioning actions.	When stopped, during CW positioning actions, or when movement is zero.	0	0
15	CW Movement	Indicates CW movement.	During CW positioning actions.	When stopped, during CCW positioning actions, or when movement is 0	0	0

\*See abbreviations list at the end of 5-3-4 Status Flags (1).

### 5-3-6 Current Position

X-Axis: Word D + 5  
 Y-Axis: Word D + 12  
 Leftmost Digits

Bit	Function	Content	Updated	Cleared	Initially	On system error
0 1 2 3	Current position (leftmost 4 digits)	Designates current position in BCD (10 <sup>4</sup> digit)	When the origin (either by ORG or CCHG) is established.	When system error occurs.	0	0
4 5 6 7		Designates current position in BCD (10 <sup>5</sup> digit)				
8 9 10 11		Designates current position in BCD (10 <sup>6</sup> digit)				
12 13 14 15		Designates current position in BCD (10 <sup>7</sup> digit)				

X-Axis: Word D + 6  
 Y-Axis: Word D + 13  
 Rightmost Digits

Bit	Function	Content	Updated	Cleared	Initially	On system error
0 1 2 3	Current position (rightmost 4 digits)	Designates current position in BCD (10 <sup>0</sup> digit)	When the origin (either by ORG or CCHG) is established.	When system error occurs.	0	0
4 5 6 7		Designates current position in BCD (10 <sup>1</sup> digit)				
8 9 10 11		Designates current position in BCD (10 <sup>2</sup> digit)				
12 13 14 15		Designates current position in BCD (10 <sup>3</sup> digit)				

### 5-3-7 M Code

X-Axis: Word D + 7  
Y-Axis: Word D + 14

Bit	Function	Content	Updated	Cleared	Initially	On system error
0 1 2 3	M code	Designates M code in BCD (10 <sup>0</sup> digit )	When execution of a positioning action with a registered M code has been completed	When execution of a positioning action without an M code has been completed or when a system error occurs.	0	0
4 5 6 7		Designates M code in BCD (10 <sup>1</sup> digit )				
8 9 10 11 12 13 14 15	Unused	Positioning actions that are set.	–	–	0	0

### 5-3-8 Multiplier and Current Positioning Action Address

X-Axis: Word D + 8  
Y-Axis: Word D + 15

Bit	Function	Content	Updated	Cleared	Initially	On system error
0 1 2 3	Current positioning action address	Designates current positioning action address in BCD (10 <sup>0</sup> digit )	When power is turned on or when SRT is executed.	–	X: 100 Y: 500	No change
4 5 6 7		Designates current positioning action address in BCD (10 <sup>1</sup> digit )				
8 9 10 11		Designates current positioning action address in BCD (10 <sup>2</sup> digit )				
12 13 14 15	Multiplier	Multiplier is designated 1, 2, or 4 in BCD.	When power is turned on or when the multiplier is changed.	–	4	No change

### 5-3-9 Current Speed Address and Override Coefficient

X-Axis: Word D + 9  
Y-Axis: Word D + 16

Bit	Function	Content	Updated	Cleared	Initially	On system error
0 1 2 3	Override coefficient	Designates $10^{-1}$ digit of override coefficient in BCD.	When OVR is received.	-	10	No change
4 5 6 7		Designates $10^0$ digit of override coefficient in BCD.				
8 9 10 11		Designates current speed address in BCD ( $10^0$ digit).				
12 13 14 15		Designates current speed address in BCD ( $10^1$ digits).				

## 5-4 Flag Changes

### Flag Changes during Positioning

For ordinary positioning, flags change in the following manner, where the flags are set during the shaded times. The M codes for the positioning actions are indicated in this example with capital letters.

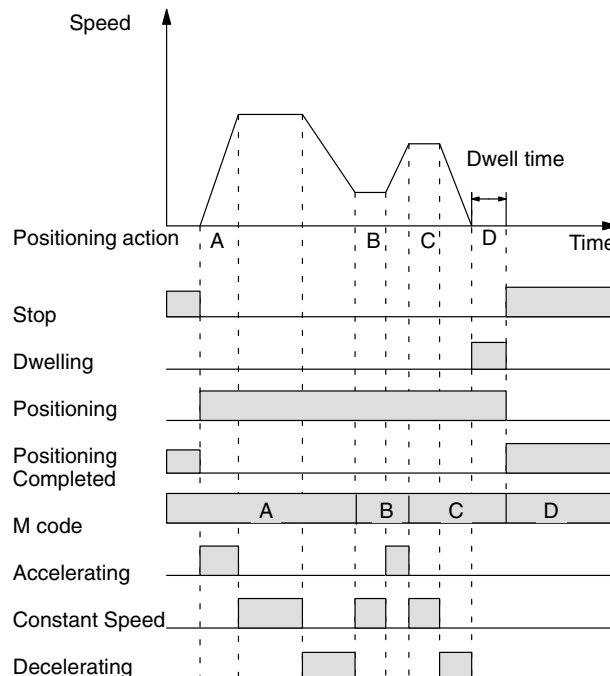

**Flag Changes during Origin Search**

During origin search, status flags change in the following manner. Flags are set during the shaded area.

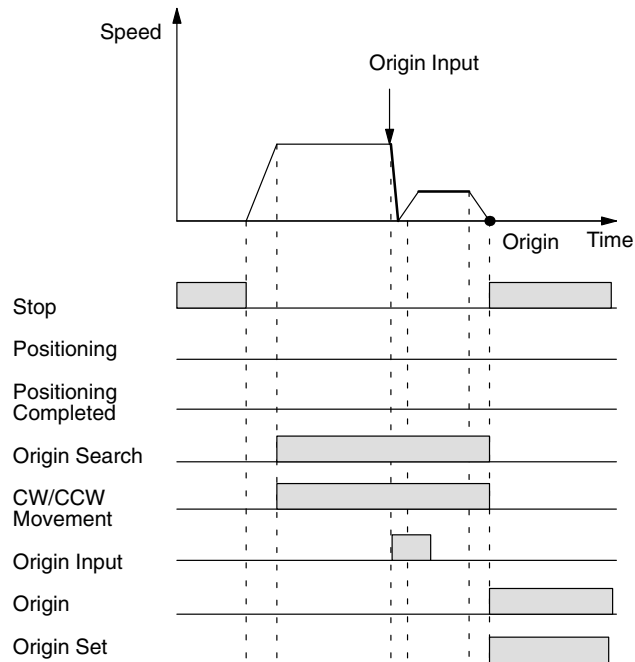

**Flag Changes during JOG**

During JOG operations, flags change in the following manner. Flags are set during the shaded areas.

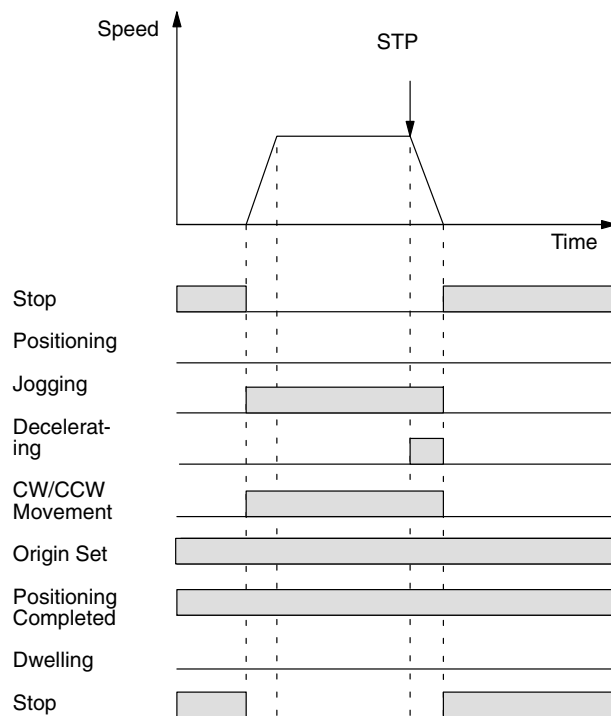



**Flag Changes for Pauses**

Flags change in the following manner when HLD (Pause) and REL (Pause Release) are executed:

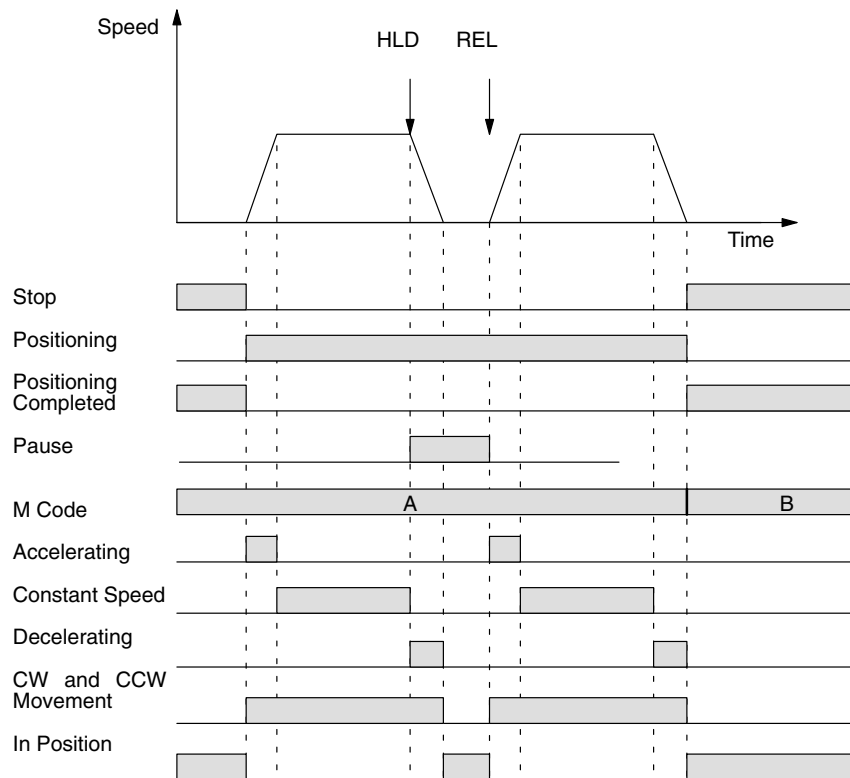

# SECTION 6

## Commands

This section describes the commands that are available to control PCU operation from the PC.

6-1	Command Format .....	82
6-2	Command Descriptions .....	84
	6-2-1 System Commands .....	84
	6-2-2 Servo Control Commands .....	85
	6-2-3 Data Processing Commands .....	87
6-3	Command Processing .....	89
6-4	Interpolation .....	90
6-5	Relation between SRT and Positioning Actions .....	95

# 6-1 Command Format

There are three types of commands used. First, four system commands support other command processing. Second, the servo control commands operate the motors. Third, data processing commands handle data stored in the Position Control Unit.

Each command comprises at least one data word with an OP code and an operand count. As the following layout shows, the OP code is unique for each command. The operand count usually designates the number (0-9) of additional data words assigned to the command. In this section, these accompanying data words are depicted below the OP code and operand word. If the number of additional data words exceeds 8, you enter 9 for the operand count, and an extra data word that follows provides the entry space for a larger operand count.

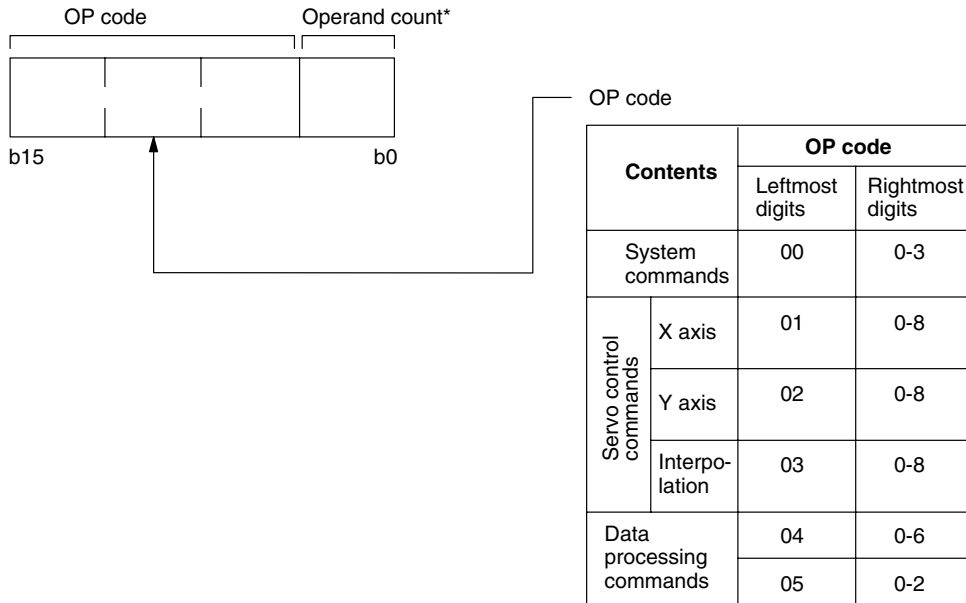

\*Operand count equals value entered here if between 0 and 8. A "9" indicates that the following word contains the count, as follows:

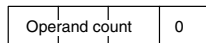
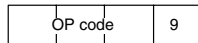

In this case, the count must be between 9 and 125.

Command OP Code Allocations and Abbreviations

—		Rightmost digit										
Type	Leftmost digits	0	1	2	3	4	5	6	7	8	9	
System commands		00	END Command end	NOP No op- eration	ERST Error re- set	OUT Exter- nal out- put con- trol	—	—	—	—	—	—
Servo control com- mands	X axis	01	XSRT Start	XSTP Decel- eration stop	XJOG Jogging	XPLS Inching	XORG Origin search	XOVR Over- ride	XHLD Pause	XREL Pause release	XEMG Emer- gency stop	—
	Y axis	02	YSRT Start	YSTP Decel- eration stop	YJOG Jogging	YPLS Inching	YORG Origin search	YOVR Over- ride	YHLD Pause	YREL Pause release	YEMG Emer- gency stop	—
	Interpol- ation	03	ISRT Start	ISTP Decel- eration stop	IJOG Jogging	IPLS Inching	IORG Origin search	IOVR Over- ride	IHLD Pause	IREL Pause release	IEMG Emer- gency stop	—
Data proceeding com- mands		04	ACLR All clear	CLR Clear	BCLR Block clear	STORE EE- PROM write (data save)	RESTR EE- PROM read	READ Data read	MOV Data transfer	—	—	—
		05	TEACH Teach- ing	CCHG Change current position	HSFT Home shift	—	—	—	—	—	—	—

## 6-2 Command Descriptions

### 6-2-1 System Commands

The following commands are used with WRITE(87) from the PC.

Name	Format	Function	Format explanation																												
Command end (END)	<p style="text-align: center;">OP code</p> <table border="1" style="margin: auto;"> <tr> <td style="text-align: center;">0</td> <td style="text-align: center;">0</td> <td style="text-align: center;">0</td> <td style="text-align: center;">0</td> </tr> </table>	0	0	0	0	Indicates the end of a command train.																									
0	0	0	0																												
No operation (NOP)	<p style="text-align: center;">OP code</p> <table border="1" style="margin: auto;"> <tr> <td style="text-align: center;">0</td> <td style="text-align: center;">0</td> <td style="text-align: center;">1</td> <td style="text-align: center;">a</td> </tr> <tr> <td colspan="3"></td> <td style="text-align: center;">b</td> </tr> <tr> <td colspan="3"></td> <td style="text-align: center;">0</td> </tr> </table>	0	0	1	a				b				0	Does not do anything, but can be used to skip commands by designating the number of words to be skipped.	a.... Operand count: 0-9 b.... Extended operand count: 009 to 125 (when a is set to 9)																
0	0	1	a																												
			b																												
			0																												
Error reset (ERST)	<p style="text-align: center;">OP code</p> <table border="1" style="margin: auto;"> <tr> <td style="text-align: center;">0</td> <td style="text-align: center;">0</td> <td style="text-align: center;">2</td> <td style="text-align: center;">0</td> </tr> </table>	0	0	2	0	Clears the error.																									
0	0	2	0																												
External output control (OUT)	<p style="text-align: center;">OP code</p> <table border="1" style="margin: auto;"> <tr> <td style="text-align: center;">0</td> <td style="text-align: center;">0</td> <td style="text-align: center;">3</td> <td style="text-align: center;">1</td> </tr> <tr> <td style="text-align: center;">0-9</td> <td style="text-align: center;">09</td> <td style="text-align: center;">0-9</td> <td style="text-align: center;">0-9</td> </tr> </table>	0	0	3	1	0-9	09	0-9	0-9	Designates external outputs ON or OFF.	<table style="margin: auto;"> <tr> <td colspan="2" style="text-align: center;">X axis</td> <td colspan="2" style="text-align: center;">Y axis</td> </tr> <tr> <td style="text-align: center;">0-9</td> <td style="text-align: center;">0-9</td> <td style="text-align: center;">0-9</td> <td style="text-align: center;">0-9</td> </tr> <tr> <td style="text-align: center;">└─┘</td> <td style="text-align: center;">└─┘</td> <td style="text-align: center;">└─┘</td> <td style="text-align: center;">└─┘</td> </tr> <tr> <td></td> <td></td> <td style="text-align: center;">OUT1 X axis</td> <td style="text-align: center;">OUT2 X axis</td> </tr> <tr> <td></td> <td></td> <td style="text-align: center;">OUT1 Y axis</td> <td style="text-align: center;">OUT2 Y axis</td> </tr> </table> <p>The corresponding output goes ON if the digit is set to 1 ; OFF, if set to 0 ; and unchanged, if 2-9.</p>	X axis		Y axis		0-9	0-9	0-9	0-9	└─┘	└─┘	└─┘	└─┘			OUT1 X axis	OUT2 X axis			OUT1 Y axis	OUT2 Y axis
0	0	3	1																												
0-9	09	0-9	0-9																												
X axis		Y axis																													
0-9	0-9	0-9	0-9																												
└─┘	└─┘	└─┘	└─┘																												
		OUT1 X axis	OUT2 X axis																												
		OUT1 Y axis	OUT2 Y axis																												

### 6-2-2 Servo Control Commands

The following commands are used with WRITE(87) for operations between the PC and PCU.

Name	Format	Function	Description	Examples																												
Start (XSRT YSRT ISRT)	<table border="1"> <tr><td colspan="4">OP code</td></tr> <tr><td>0</td><td>A</td><td>0</td><td>a</td></tr> <tr><td></td><td></td><td>b</td><td>0</td></tr> <tr><td></td><td></td><td>c</td><td>0</td></tr> </table>	OP code				0	A	0	a			b	0			c	0	Positioning is executed according to a positioning action as specified by the operand.	A.....Axis designation 1: X axis 2: Y axis 3: Both axes  a.....Operand number 0: Address specified according to internal address counter. 1 to 8: Operand number 9: Extension operand designation  b.....Positioning action address (when a = 1 to 8)  b.....Extension operand number 009 to 125 (when a = 9)  c.....Positioning action address	<table border="1"> <tr><td>0</td><td>1</td><td>0</td><td>2</td></tr> <tr><td>1</td><td>0</td><td>0</td><td>0</td></tr> <tr><td>1</td><td>0</td><td>2</td><td>0</td></tr> </table> Executing start with X-axis addresses 100 and 102.	0	1	0	2	1	0	0	0	1	0	2	0
OP code																																
0	A	0	a																													
		b	0																													
		c	0																													
0	1	0	2																													
1	0	0	0																													
1	0	2	0																													
Deceleration stop (XSTP YSTP ISTP)	<table border="1"> <tr><td colspan="4">OP code</td></tr> <tr><td>0</td><td>A</td><td>1</td><td>1</td></tr> <tr><td>0</td><td>0</td><td>a</td><td>0</td></tr> </table>	OP code				0	A	1	1	0	0	a	0	Stops designated axes according to the designated acceleration and deceleration patterns.	A.....Axis designation 1: X axis 2: Y axis 3: both axes  a.....Acceleration and deceleration patterns: 0 to 9	<table border="1"> <tr><td>0</td><td>3</td><td>1</td><td>1</td></tr> <tr><td>0</td><td>0</td><td>2</td><td>0</td></tr> </table> Executing deceleration stop, along both axes, with acceleration/deceleration pattern 2 (addresses 462 and 862).	0	3	1	1	0	0	2	0								
OP code																																
0	A	1	1																													
0	0	a	0																													
0	3	1	1																													
0	0	2	0																													
Jogging (XJOG YJOG IJOG)	<table border="1"> <tr><td colspan="4">OP code</td></tr> <tr><td>0</td><td>A</td><td>2</td><td>2</td></tr> <tr><td>0</td><td></td><td>a</td><td>b</td></tr> <tr><td>0</td><td>0</td><td>c</td><td>0</td></tr> </table>	OP code				0	A	2	2	0		a	b	0	0	c	0	Instructs jogging for designated axes.	A.....Axis designation 1: X axis 2: Y axis 3: Both axes  a.....Speed data: 00 to 99  b.....Feeding direction 0: + direction 1: - direction  c.....Acceleration and deceleration patterns: 0 to 9	<table border="1"> <tr><td>0</td><td>3</td><td>2</td><td>2</td></tr> <tr><td>0</td><td>1</td><td>2</td><td>0</td></tr> <tr><td>0</td><td>0</td><td>2</td><td>0</td></tr> </table> Jogging in the + direction, along both axes, with speed no. 12 (address 912) and acceleration/deceleration pattern 2 (addresses 462 and 862).	0	3	2	2	0	1	2	0	0	0	2	0
OP code																																
0	A	2	2																													
0		a	b																													
0	0	c	0																													
0	3	2	2																													
0	1	2	0																													
0	0	2	0																													
Inching (XPLS YPLS IPLS)	<table border="1"> <tr><td colspan="4">OP code</td></tr> <tr><td>0</td><td>A</td><td>3</td><td>1</td></tr> <tr><td></td><td></td><td>a</td><td>b</td></tr> </table>	OP code				0	A	3	1			a	b	Moves the designated axis the designated number of pulses. All pulses are transmitted in one string.	A.....Axis designation 1: X axis 2: Y axis 3: Both axes  a.....Number of pulses (000 to 999)  b.....Feeding direction 0: + direction 1: - direction	<table border="1"> <tr><td>0</td><td>1</td><td>3</td><td>1</td></tr> <tr><td>1</td><td>0</td><td>0</td><td>0</td></tr> </table> Inching for 100 pulses, along the X axis, in the + direction.	0	1	3	1	1	0	0	0								
OP code																																
0	A	3	1																													
		a	b																													
0	1	3	1																													
1	0	0	0																													
Origin search (XORG YORG IORG)	<table border="1"> <tr><td colspan="4">OP code</td></tr> <tr><td>0</td><td>A</td><td>4</td><td>0</td></tr> </table>	OP code				0	A	4	0	Performs origin search on designated axes.	A.....Axis designation 1: X axis 2: Y axis 3: Both axes	<table border="1"> <tr><td>0</td><td>3</td><td>4</td><td>0</td></tr> </table> Determining the origin along both axes.	0	3	4	0																
OP code																																
0	A	4	0																													
0	3	4	0																													
Override (XOVR YOVR IOVR)	<table border="1"> <tr><td colspan="4">OP code</td></tr> <tr><td>0</td><td>A</td><td>5</td><td>1</td></tr> <tr><td></td><td></td><td>a</td><td>0</td></tr> </table>	OP code				0	A	5	1			a	0	Designates the override coefficient for the positioning speed.	A.....Axis designation 1: X axis 2: Y axis 3: Both axes  a.....Override coefficient: 0001 to 9999 (0.1% units)	<table border="1"> <tr><td>0</td><td>2</td><td>5</td><td>1</td></tr> <tr><td>1</td><td>5</td><td>0</td><td>0</td></tr> </table> Designating 150% as the override coefficient along the Y axis.	0	2	5	1	1	5	0	0								
OP code																																
0	A	5	1																													
		a	0																													
0	2	5	1																													
1	5	0	0																													

Name	Format	Function	Description	Examples				
Pause ( XHLD ) ( YHLD ) ( IHLD )	OP code 0   A   6   0	Pauses positioning	A.....Axis designation 1: X axis 2: Y axis 3: Both axes	<table border="1" data-bbox="1222 212 1425 254"> <tr> <td>0</td> <td>1</td> <td>6</td> <td>0</td> </tr> </table> Executing a pause on the X axis.	0	1	6	0
0	1	6	0					
Pause release ( XREL ) ( YREL ) ( IREL )	OP code 0   A   7   0	Releases pause on positioning	A.....Axis designation 1: X axis 2: Y axis 3: Both axes	<table border="1" data-bbox="1222 396 1425 438"> <tr> <td>0</td> <td>1</td> <td>7</td> <td>0</td> </tr> </table> Releasing the pause on the X axis.	0	1	7	0
0	1	7	0					
Emergency stop ( XEMG ) ( YEMG ) ( IEMG )	OP code 0   A   8   0	Executes an emergency stop for the designated axis. Works the same as an external interrupt.	A.....Axis designation 1: X axis 2: Y axis 3: Both axes	<table border="1" data-bbox="1222 575 1425 617"> <tr> <td>0</td> <td>3</td> <td>8</td> <td>0</td> </tr> </table> Executing an emergency stop on both axes.	0	3	8	0
0	3	8	0					

### 6-2-3 Data Processing Commands

The following commands are used with WRITE(87) for operations within the PCU.

Name	Format	Function	Description	Examples																								
All clear (ACLR)	<p>OP code</p> <table border="1"> <tr><td>0</td><td>4</td><td>0</td><td>1</td></tr> <tr><td>0</td><td>a</td><td>b</td><td>c</td></tr> </table>	0	4	0	1	0	a	b	c	Clears all data designated by the operand.	<p>a.....Speed data 0: Does not clear 1: Clears</p> <p>b.....Parameter data 0: Does not clear 1: Clears X axis 2: Clears Y axis 3: Clears both axes</p> <p>c.....Positioning data: Same as b.</p>	<table border="1"> <tr><td>0</td><td>4</td><td>0</td><td>1</td></tr> <tr><td>0</td><td>1</td><td>3</td><td>3</td></tr> </table> <p>Clearing all data.</p>	0	4	0	1	0	1	3	3								
0	4	0	1																									
0	a	b	c																									
0	4	0	1																									
0	1	3	3																									
Clear (CLR)	<p>OP code</p> <table border="1"> <tr><td>0</td><td>4</td><td>1</td><td>a</td></tr> <tr><td></td><td>b</td><td></td><td>0</td></tr> <tr><td></td><td>c</td><td></td><td>0</td></tr> </table>	0	4	1	a		b		0		c		0	Clears the data from the designated addresses.	<p>a.....Operand number 1 to 8: Operand number 9: Extension operand designation</p> <p>b.....Address to be cleared (when a = 1 to 8)</p> <p>b.....Extension operand number: 009 to 125 (when a = 9)</p> <p>c.....Address to be cleared</p>	<table border="1"> <tr><td>0</td><td>4</td><td>1</td><td>2</td></tr> <tr><td>1</td><td>0</td><td>0</td><td>0</td></tr> <tr><td>5</td><td>0</td><td>0</td><td>0</td></tr> </table> <p>Clearing positioning action addresses 100 and 500.</p>	0	4	1	2	1	0	0	0	5	0	0	0
0	4	1	a																									
	b		0																									
	c		0																									
0	4	1	2																									
1	0	0	0																									
5	0	0	0																									
Block clear (BCLR)	<p>OP code</p> <table border="1"> <tr><td>0</td><td>4</td><td>2</td><td>2</td></tr> <tr><td></td><td>a</td><td></td><td>0</td></tr> <tr><td></td><td>b</td><td></td><td>0</td></tr> </table>	0	4	2	2		a		0		b		0	Clears the data in the range of addresses designated by the operand (as long as the data is of the same type).	<p>a.....Beginning address to be cleared</p> <p>b.....End address to be cleared</p>	<table border="1"> <tr><td>0</td><td>4</td><td>2</td><td>2</td></tr> <tr><td>1</td><td>0</td><td>0</td><td>0</td></tr> <tr><td>3</td><td>9</td><td>9</td><td>0</td></tr> </table> <p>Clearing all positioning actions on the X axis from addresses 100 to 399.</p>	0	4	2	2	1	0	0	0	3	9	9	0
0	4	2	2																									
	a		0																									
	b		0																									
0	4	2	2																									
1	0	0	0																									
3	9	9	0																									
Write EE-PROM (STORE)	<p>OP code</p> <table border="1"> <tr><td>0</td><td>4</td><td>3</td><td>1</td></tr> <tr><td>0</td><td>a</td><td>b</td><td>c</td></tr> </table>	0	4	3	1	0	a	b	c	Writes data from internal RAM to EE-PROM.	<p>a.....Speed data 0: Does not write 1: Writes</p> <p>b.....Parameter data 0: Does not write 1: Writes X axis data 2: Writes Y axis data 3: Writes data from both axes</p> <p>c.....Position data: Same as b.</p>	<table border="1"> <tr><td>0</td><td>4</td><td>3</td><td>1</td></tr> <tr><td>0</td><td>1</td><td>1</td><td>1</td></tr> </table> <p>Writing all X axis data to EEPROM.</p>	0	4	3	1	0	1	1	1								
0	4	3	1																									
0	a	b	c																									
0	4	3	1																									
0	1	1	1																									
Read EE-PROM (RESTR)	<p>OP code</p> <table border="1"> <tr><td>0</td><td>4</td><td>4</td><td>1</td></tr> <tr><td>0</td><td>a</td><td>b</td><td>c</td></tr> </table>	0	4	4	1	0	a	b	c	Reads data from EEPROM to internal RAM. This command executes automatically when power is turned on so that all data is read.	<p>a.....Speed data 0: Does not read 1: Reads</p> <p>b.....Parameter data 0: Does not read 1: Reads X axis data 2: Reads Y axis data 3: Reads data from both axes</p> <p>c.....Position data: Same as b.</p>	<table border="1"> <tr><td>0</td><td>4</td><td>4</td><td>1</td></tr> <tr><td>0</td><td>1</td><td>2</td><td>2</td></tr> </table> <p>Reading all Y axis data to internal RAM.</p>	0	4	4	1	0	1	2	2								
0	4	4	1																									
0	a	b	c																									
0	4	4	1																									
0	1	2	2																									
Read data (READ)	<p>OP code</p> <table border="1"> <tr><td>0</td><td>4</td><td>5</td><td>2</td></tr> <tr><td></td><td>a</td><td></td><td>0</td></tr> <tr><td></td><td>b</td><td></td><td>0</td></tr> </table>	0	4	5	2		a		0		b		0	Reads data from the designated data addresses to the status readout area (words 17 to 126). Does not read out the addresses themselves.	<p>a.....Start address for read</p> <p>b.....Number of addresses to be read.</p>	<table border="1"> <tr><td>0</td><td>4</td><td>5</td><td>2</td></tr> <tr><td>1</td><td>0</td><td>0</td><td>0</td></tr> <tr><td>0</td><td>1</td><td>0</td><td>0</td></tr> </table> <p>Reading the contents of X axis positioning action addresses 100 to 109.</p>	0	4	5	2	1	0	0	0	0	1	0	0
0	4	5	2																									
	a		0																									
	b		0																									
0	4	5	2																									
1	0	0	0																									
0	1	0	0																									



Name	Format	Function	Description	Examples																																
Transfer data (MOV)	<p>OP code</p> <table border="1"> <tr><td>0</td><td>4</td><td>6</td><td>2</td></tr> <tr><td>a</td><td></td><td></td><td>0</td></tr> <tr><td>b</td><td></td><td></td><td>0</td></tr> </table>	0	4	6	2	a			0	b			0	Transfers data within internal RAM.	a.....Source address b.....Destination address	<table border="1"> <tr><td>0</td><td>4</td><td>6</td><td>2</td></tr> <tr><td>1</td><td>0</td><td>0</td><td>0</td></tr> <tr><td>1</td><td>0</td><td>1</td><td>0</td></tr> </table> <p>Transferring contents of X-axis positioning action address 100 to address 101.</p>	0	4	6	2	1	0	0	0	1	0	1	0								
0	4	6	2																																	
a			0																																	
b			0																																	
0	4	6	2																																	
1	0	0	0																																	
1	0	1	0																																	
Block transfer (BMOV)	<p>OP code</p> <table border="1"> <tr><td>0</td><td>4</td><td>6</td><td>3</td></tr> <tr><td>a</td><td></td><td></td><td>0</td></tr> <tr><td>b</td><td></td><td></td><td>0</td></tr> <tr><td>c</td><td></td><td></td><td>0</td></tr> </table>	0	4	6	3	a			0	b			0	c			0	Transfers multiple data words within internal RAM.	a.....Source start address b.....Source end address c.....Number of addresses to be moved.	<table border="1"> <tr><td>0</td><td>4</td><td>6</td><td>3</td></tr> <tr><td>1</td><td>0</td><td>0</td><td>0</td></tr> <tr><td>2</td><td>0</td><td>0</td><td>0</td></tr> <tr><td>0</td><td>1</td><td>0</td><td>0</td></tr> </table> <p>Transferring 10 positioning actions from address 100 (and up) to address 200 (and up).</p>	0	4	6	3	1	0	0	0	2	0	0	0	0	1	0	0
0	4	6	3																																	
a			0																																	
b			0																																	
c			0																																	
0	4	6	3																																	
1	0	0	0																																	
2	0	0	0																																	
0	1	0	0																																	
Teaching (TEACH)	<p>OP code</p> <table border="1"> <tr><td>0</td><td>5</td><td>0</td><td>1</td></tr> <tr><td>a</td><td></td><td></td><td>A</td></tr> </table>	0	5	0	1	a			A	Stores current position for designated axis as the position for a positioning action.	a.....Positioning action address A.....Axis designation 1: X axis 2: Y axis 3: Interpolation  When using interpolation, designate the address for the X axis in a; the current position will also be set for the corresponding Y axis.	<table border="1"> <tr><td>0</td><td>5</td><td>0</td><td>1</td></tr> <tr><td>5</td><td>0</td><td>0</td><td>2</td></tr> </table> <p>Storing the current position in Y-axis address 500.</p>	0	5	0	1	5	0	0	2																
0	5	0	1																																	
a			A																																	
0	5	0	1																																	
5	0	0	2																																	
Data teaching (DTEACH)	<p>OP code</p> <table border="1"> <tr><td>0</td><td>5</td><td>0</td><td>3</td></tr> <tr><td>a</td><td></td><td></td><td>A</td></tr> <tr><td>b</td><td></td><td>c</td><td></td></tr> <tr><td>d</td><td>e</td><td>f</td><td>g</td></tr> </table>	0	5	0	3	a			A	b		c		d	e	f	g	Stores current position for designated axis along with all non-position fields as a positioning action.	a.....Positioning action address A.....Axis designation 1: X axis 2: Y axis 3: Interpolation b.....Speed address: 00 to 99 c.....M code: 00 to 99 d.....Dwell time address: 0 to 9 e.....Acceleration/deceleration pattern: 0 to 9 f.....Attributes: 0 to F g.....Positioning pattern: 0 to 7	<table border="1"> <tr><td>0</td><td>5</td><td>0</td><td>3</td></tr> <tr><td>1</td><td>0</td><td>0</td><td>3</td></tr> <tr><td>0</td><td>1</td><td>2</td><td>3</td></tr> <tr><td>2</td><td>0</td><td>4</td><td>0</td></tr> </table> <p>Storing the current position, with the designated attributes, in X-axis address 100 and Y-axis address 500.</p>	0	5	0	3	1	0	0	3	0	1	2	3	2	0	4	0
0	5	0	3																																	
a			A																																	
b		c																																		
d	e	f	g																																	
0	5	0	3																																	
1	0	0	3																																	
0	1	2	3																																	
2	0	4	0																																	
Change current position (CCHG)	<p>OP code</p> <table border="1"> <tr><td>0</td><td>5</td><td>1</td><td>3</td></tr> <tr><td>0</td><td>0</td><td>a</td><td>A</td></tr> <tr><td>x10<sup>7</sup></td><td>x10<sup>6</sup></td><td>x10<sup>5</sup></td><td>x10<sup>4</sup></td></tr> <tr><td>x10<sup>3</sup></td><td>x10<sup>2</sup></td><td>x10<sup>1</sup></td><td>x10<sup>0</sup></td></tr> </table>	0	5	1	3	0	0	a	A	x10 <sup>7</sup>	x10 <sup>6</sup>	x10 <sup>5</sup>	x10 <sup>4</sup>	x10 <sup>3</sup>	x10 <sup>2</sup>	x10 <sup>1</sup>	x10 <sup>0</sup>	Changes the contents of the current position to the designated value for the designated axis.	a.....Direction digit 0: + 1: -  A.....Axis designation 1: X axis 2: Y axis	<table border="1"> <tr><td>0</td><td>5</td><td>1</td><td>3</td></tr> <tr><td>0</td><td>0</td><td>0</td><td>1</td></tr> <tr><td>0</td><td>0</td><td>0</td><td>5</td></tr> <tr><td>0</td><td>0</td><td>0</td><td>0</td></tr> </table> <p>Changing the contents of the current position on the X-axis to +50,000.</p>	0	5	1	3	0	0	0	1	0	0	0	5	0	0	0	0
0	5	1	3																																	
0	0	a	A																																	
x10 <sup>7</sup>	x10 <sup>6</sup>	x10 <sup>5</sup>	x10 <sup>4</sup>																																	
x10 <sup>3</sup>	x10 <sup>2</sup>	x10 <sup>1</sup>	x10 <sup>0</sup>																																	
0	5	1	3																																	
0	0	0	1																																	
0	0	0	5																																	
0	0	0	0																																	
Home shift (HSFT)	<p>OP code</p> <table border="1"> <tr><td>0</td><td>5</td><td>2</td><td>1</td></tr> <tr><td>0</td><td>0</td><td>a</td><td>b</td></tr> </table>	0	5	2	1	0	0	a	b	When the digit in the designated data word field is 1, home shift is enabled for positioning that follows.	a.....X axis home shift 0: Disabled 1: Enabled 2 to 9: Maintains present condition  b.....X axis home shift Same as a.	<table border="1"> <tr><td>0</td><td>5</td><td>2</td><td>1</td></tr> <tr><td>0</td><td>0</td><td>1</td><td>1</td></tr> </table> <p>Enabling home shift for both axes.</p>	0	5	2	1	0	0	1	1																
0	5	2	1																																	
0	0	a	b																																	
0	5	2	1																																	
0	0	1	1																																	

### 6-3 Command Processing

The various commands have the following processing conditions.

Command	Processing condition	Other conditions
END NOP, OUT XOVR, YOVR, KIOVR XEMG, YEMG, IEMG ERST	When Command Ready flag is ON.	The command is ignored.
XHLD, YHLD, IHLD XSTP, YSTP, ISTP	While Position Control Unit is operating.	The command is ignored.
XREL, YREL, IREL	While XHLD, YHLD, or IHLD is ON.	The command is ignored.
XSRT, YSRT, ISRT XJOG, YJOG, IJOG XPLS, YPLS, IPLS XORG, YORG, IORG ACLR, CLR, BCLR STORE, RESTR READ, MOV TEACH, DTEACH CCHG HSFT	While Position Control Unit is stopped.	Command error occurs.

**Start Command Delays**

The time required from when a start command is received until a speed voltage is output is as follows:

Normally: Approx. 6 ms.

When one axis is started while the other one is moving or when data reads or other time-consuming processes are being handled: 10 ms.

**Relationship between Flags and Commands**

The following table shows which commands are valid when certain flags are ON. These are indicated as follows:

- ∅ Command acknowledged.
- X Command ignored.
- ⊗ Command error results.

Condition Command	Positioning	Stop	Origin Search	Deceleration Stop	Jogging	Inching	Pause	Emergency Stops	Upon initialization
END	∅	∅	∅	∅	∅	∅	∅	∅	∅
NOP	∅	∅	∅	∅	∅	∅	∅	∅	∅
ERST	∅	∅	∅	∅	∅	∅	∅	∅	∅
OUT	∅	∅	∅	∅	∅	∅	∅	∅	∅
SRT	⊗	∅	⊗	⊗	⊗	⊗	⊗	X	⊗
STP	∅	X	∅	∅	∅	∅	∅*1	X	X
JOG	⊗	∅	⊗	⊗	⊗	⊗	⊗	X	∅
PLS	⊗	∅	⊗	⊗	⊗	⊗	⊗	X	∅
ORG	⊗	∅	⊗	⊗	⊗	⊗	⊗	X	∅
OVR	∅	∅*2	∅	∅*2	∅	∅*2	∅*2	∅*2	∅*2
HLD	∅	X	∅	∅	∅	X	∅	X	X

Condition Command	Positioning	Stop	Origin Search	Deceleration Stop	Jogging	Inching	Pause	Emergency Stops	Upon initialization
REL	X	X	X	X	X	X	X	X	X
EMG	∅	∅	∅	∅	∅	∅	∅	X	∅
ACLR	⊗	∅	⊗	⊗	⊗	⊗	⊗	∅	∅
CLR	⊗	∅	⊗	⊗	⊗	⊗	⊗	∅	∅
BCLR	⊗	∅	⊗	⊗	⊗	⊗	⊗	∅	∅
STORE	⊗	∅	⊗	⊗	⊗	⊗	⊗	∅	∅
RESTR	⊗	∅	⊗	⊗	⊗	⊗	⊗	∅	∅
READ	∅	∅	∅	∅	∅	∅	∅	∅	∅
MOV	⊗	∅	⊗	⊗	⊗	⊗	⊗	∅	∅
TEACH	⊗	∅	⊗	⊗	⊗	⊗	⊗	∅	∅
CCHG	⊗	∅	⊗	⊗	⊗	⊗	⊗	X	∅
HSFT	⊗	∅	⊗	⊗	⊗	⊗	⊗	∅	∅

\*1: Clears HLD and stops.

\*2: The command is acknowledged, but is effective from the next SRT.

## 6-4 Interpolation

For interpolated positioning, both X and Y motor axes operate together. Although the position field is used for both the X- and Y-axis positioning actions, all other positioning action parameters are taken from the X-axis fields only, and corresponding Y-axis fields are ignored.

For example, in the circular arc interpolation below the intermediate interpolation point P<sub>0</sub> and end point P<sub>1</sub> are selected.

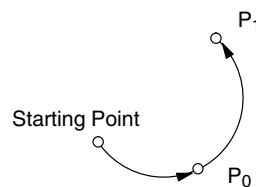

Consider the command:

0	3	0	1	← Interpolation start with one operand
1	2	3	0	← Positioning action designating intermediate interpolation point

The OP code designates ISRT (interpolation start) with an operand count of 1 referring to the word for the single positioning action immediately below. The address 123 is an X-axis positioning action and assumed to be the intermediate interpolation point. The corresponding Y-axis positioning action is 523 (same last two digits). You must set the positioning action address with the circular arc interpolation command as the intermediate interpolation point. The end point will automatically be searched in the address following the interpolation point address.

Position	Positioning action		X-axis data	Y-axis data	During interpolation	Remarks
P <sub>0</sub>	Address		123	523	X=123 Y= 523	X-axis and Y-axis addresses automatically correspond through their last two digits.
	Position		P <sub>0</sub> (x)	P <sub>0</sub> (y)	X= P <sub>0</sub> (x) Y= P <sub>0</sub> (y)	Positive
	Speed		V <sub>0ad</sub> (x)	V <sub>0ad</sub> (y)	V <sub>0ad</sub> (x)	100 <-> 500 101 <-> 501
	M code		M <sub>0</sub> (x)	M <sub>0</sub> (y)	There is no M code.	⋮
	Dwell time		DT <sub>0</sub> (x)	DT <sub>0</sub> (y)	Dwelling is disabled.	399 <-> 799
	Accel./decel. time		PT <sub>0</sub> (x)	PT <sub>0</sub> (y)	–	
	Attribute 1	Position field sign	Positive	Positive	Positive	
		Position type	ABS	ABS	ABS	
		Interpolation code	Intermediate point	No interpolation	Intermediate point	
	Attribute 2	Completion code	0	0	0	–
Circular arc interpolation direction		CW	CCW	Automatically determined		
Positioning action enable		Enabled	Enabled	Enabled	X and Y axes must both be enabled to avoid an error.	
P <sub>1</sub>	Address		124	524	X=124 Y= 524	–
	Position		P <sub>1</sub> (x)	P <sub>1</sub> (y)	X=P <sub>1</sub> (x) Y=P <sub>1</sub> (y)	
	Speed		V <sub>1ad</sub> (x)	V <sub>1ad</sub> (y)	V <sub>0ad</sub> (x)	
	M code		M <sub>1</sub> (x)	M <sub>1</sub> (y)	M <sub>1</sub> (x)	
	Dwell time		DT <sub>1</sub> (x)	DT <sub>1</sub> (y)	DT <sub>1</sub> (x)	
	Accel./decel. time		PT <sub>1</sub> (x)	PT <sub>1</sub> (y)	–	
	Attribute 1	Position field sign	Positive	Positive	Positive	
		Position type	ABS	ABS	ABS	
		Interpolation code	End point	Circular arc center	End point	
	Attribute 2	Completion code	0	0	0	
		Circular arc interpolation direction	CW	CW	CW	
		Positioning action enable	Enabled	Enabled	Enabled	

### Circular Arc Interpolation

#### Incremental Positions

When using incremental positions for circular arc interpolation, the increments for the intermediate or center point are measured from the starting point and the increments for the end point are measured from the intermediate or center point.

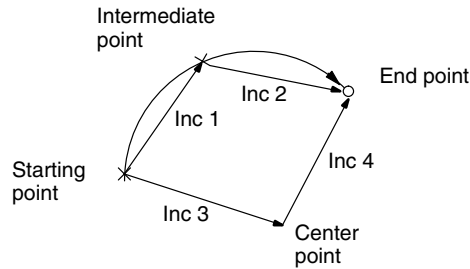

#### Program Example

The following table presents a short list of hypothetical positioning actions. For specific field entries, refer to 3-4 *Setting Positioning Actions*.

Address	Position	Interpolation Code	Positioning Action Enable
123	P <sub>0</sub> X	10 <sup>*1</sup>	1 (Enabled)
124	P <sub>1</sub> X	01 <sup>*2</sup>	1 (Enabled)
125	P <sub>2</sub> X	10 <sup>*1</sup>	1 (Enabled)
126	P <sub>3</sub> X	01 <sup>*2</sup>	1 (Enabled)

Completion code	Address	Position
1	523	P <sub>0</sub> Y
1	524	P <sub>1</sub> Y
0	525	P <sub>2</sub> Y
0	526	P <sub>3</sub> Y

\*1: Circular arc intermediate point

\*2: Interpolation end point

#### ISRT from Address 123

The figure below shows the resulting operation.

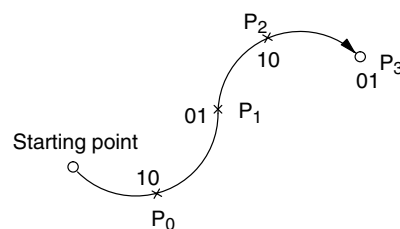

**ISRT with Address 124 Disabled**

In this case the positioning action of address 124 is processed normally since it is an end point; furthermore, address 123 remains enabled as an intermediate point. The entire operation proceeds normally.

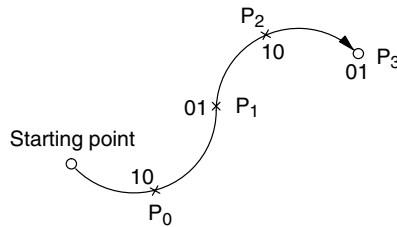

**ISRT with Improper Interpolation Codes**

In this case a circular arc cannot be created with the designated positions, and a circular arc data error occurs. Remember, two consecutive positioning actions must comprise circular arc positioning. The first address must store the circular arc center (interpolation code 11) or circular arc intermediate point (interpolation code 10), and the second address must store the interpolation end point (interpolation code 01).

**Straight-Line Interpolation**

The following table presents a hypothetical list of positioning actions all with interpolation code 01 (as end points). The accompanying figure shows two interpolation routes. The solid line from the starting point to P<sub>1</sub> and then to P<sub>3</sub> obeys data in the table, because addresses 200 and 202 are disabled. If all addresses 200-203 were all enabled, positioning would follow the broken line in the figure.

Address	Position	Interpolation Code	Positioning Action enabled
200	P <sub>0</sub> X	01	Enabled
201	P <sub>1</sub> X	01	Disabled
202	P <sub>2</sub> X	01	Enabled
203	P <sub>3</sub> X	01	Disabled

Completion code	Address	Position
1	600	P <sub>0</sub> X
1	601	P <sub>1</sub> X
1	602	P <sub>2</sub> X
0	603	P <sub>3</sub> X

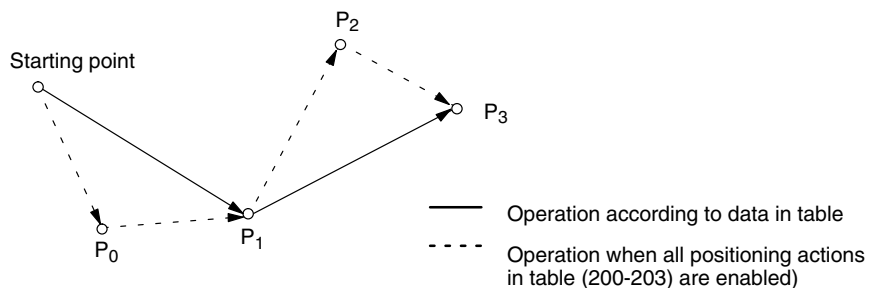

## Interpolation Speeds

The speed set for the X axis will be used for linear and circular interpolation. For circular arc interpolation, this speed will be the speed along the tangent to the arc, as shown below.

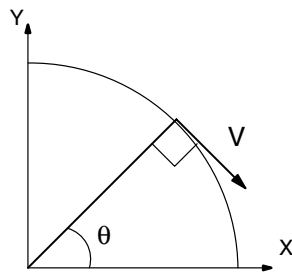

For linear interpolation, the speeds along the X and Y axes can be figured as follows:

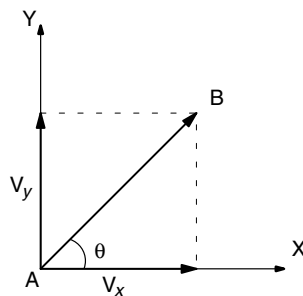

$$V_x = V \cos \theta$$

$$V_y = V \sin \theta$$

## 6-5 Relation between SRT and Positioning Actions

The following table shows the positioning action fields pertinent to execution of XSRT, YSRT, and ISRT which initiate X-axis positioning, Y-axis positioning, and interpolated (both X and Y axes) positioning, respectively. If any pertinent fields have erroneous data, then a command error occurs. Designating XSRT or YSRT for interpolated positioning actions will refer only to the respective X or Y positioning actions. Only a single axis will operate.

Key. \*: Data in this field is used. -: Data in this field unused. 0/1: Fixed data for the particular operation.

Axis	Field or field bit	X-axis positioning	Y-axis positioning	X-axis continuous positioning		Straight line interpolation	Continuous straight-line interpolation		Circular arc interpolation (using intermediate point)		Circular arc interpolation (using center)	
				First address	Next address		First address	Next address	First address	Next address	First address	Next address
X	Position	*		*	*	*	*	*	*	*	*	*
	Speed	*		*	*	*	*	*	*	-	*	*
	M code	*		*	*	*	*	*	-	*	-	*
	Dwell time	*		-	*	*	-	*	-	*	-	*
	Acceleration and deceleration time	*		*	*	*	*	*	**	-	*	-
	Interpolation code	00		00	00	01	01	01	10	01	11	01
	Position type	*		*	*	*	*	*	*	*	*	*
	Position field sign 1	*		*	*	*	*	*	*	*	*	*
	Positioning action enable	1		1	1	1	1	1	1	-	1	-
	Circular arc interpolation direction	-		-	-	-	-	-	-	-	*	-
Completion code	0		1	0	0	1	0	0/1	-	0/1	-	
Y	Position		*			*	*	*	*	*	*	*
	Speed		*			-	-	-	-	-	-	-
	M code		*			-	-	-	-	-	-	-
	Dwell time		*			-	-	-	-	-	-	-
	Acceleration and deceleration time		*			-	-	-	-	-	-	-
	Interpolation code		00			-	-	-	-	-	-	-
	Position type		*			*	*	*	*	*	*	*
	Position field sign		*			*	*	*	*	*	*	*
	Positioning action enable		1			1	1	1	1	-	1	-
	Circular arc interpolation direction		-			-	-	-	-	-	-	-
Completion code		0			-	-	-	-	-	-	-	



# SECTION 7

## Establishing the Origin

The section describes how to establish the origin, either by defining the current position as the origin or by using origin and limit inputs to establish the mechanical origin.

7-1	CCHG .....	98
7-2	Origin Search (XORG, YORG, IORG) .....	98
7-3	Origin Compensation .....	100

## 7-1 CCHG

Before positioning, it is necessary to establish the origin as a reference point, by means of either CCHG (changing current position) or ORG (origin search). Use CCHG if it is difficult to establish the origin inputs mechanically or if you constantly need to re-establish the origin. Turn on the power, and move the workpiece to the desired origin position by jogging (JOG) or inching (PLS). Enter 0 with the CCHG command to establish the current position as the origin. CCHG is only effective when not positioning. During operation CCHG causes a command error.

## 7-2 Origin Search (XORG, YORG, IORG)

Origin search establishes the absolute mechanical origin with the origin search commands XORG, YORG or IORG by using the CW and CCW limits (Refer to *Section 6 Commands*). This function establishes the origin at the phase Z of the encoder based on the origin input.

When the origin search starts, the dog approaches the origin input at the high origin search speed (parameter stored at addresses 415 for the X axis and 815 for the Y axis). At the leading edge of the origin input, the speed slows and movement comes to a halt and then movement starts again at the low origin search speed (parameter stored at addresses 417 for the X axis and 817 for the Y axis). The motor axis (or axes) stops at the first phase Z pulse after the origin input goes OFF during the low origin search speed. Any movement beyond the edge due to inertia is corrected by reverse movement.

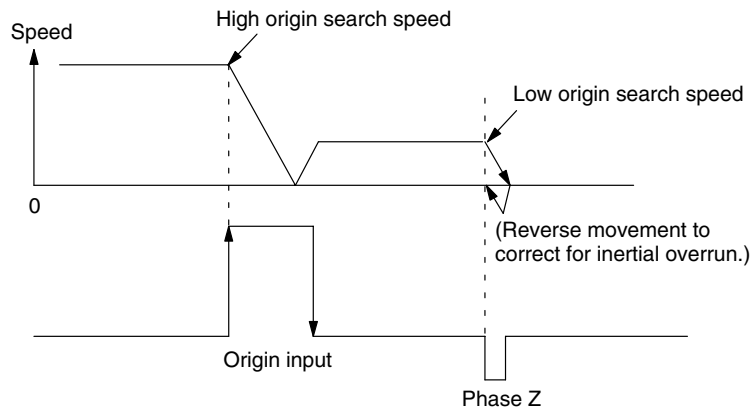

(First phase Z pulse after origin input goes OFF during low origin search speed.)

For accurate origin search use a dog with a sufficient length to allow deceleration from the high origin search speed to the low origin search speed. If the dog is too short use a lower high origin search speed.

### Search Patterns

There are three origin search patterns possible according to the dog position at the start of the search and the search direction parameter. The following examples all search clockwise. These three patterns are possible for counterclockwise searches as well.

#### Search Starting on Origin Input

1. Movement starts in the direction opposite to the search direction at low origin search speed.
2. Movement stops and reverses direction at the trailing edge of the origin input.

3. The origin is established at the first phase Z pulse after the leading and trailing edges of the origin input.

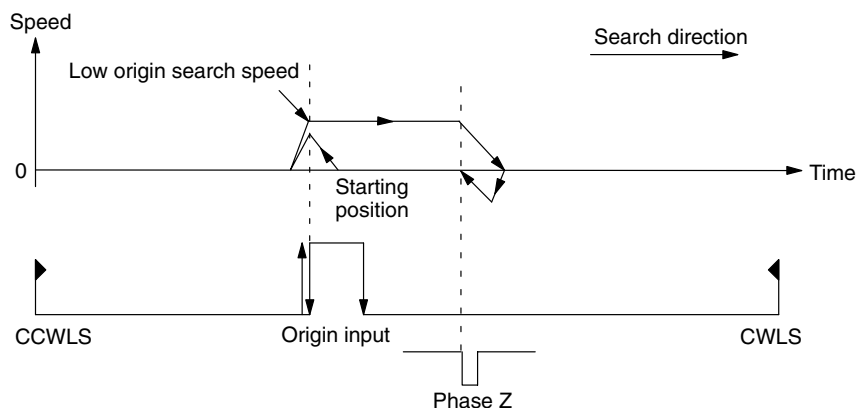

**Search Starting between CCW Limit Input and Origin Input**

- 1, 2, 3... 1. Movement starts in the search direction at high origin search speed.
2. Movement slows to low origin search speed at the leading edge of the origin input.
3. The origin is established at the first phase Z pulse after the trailing edge of the origin input.

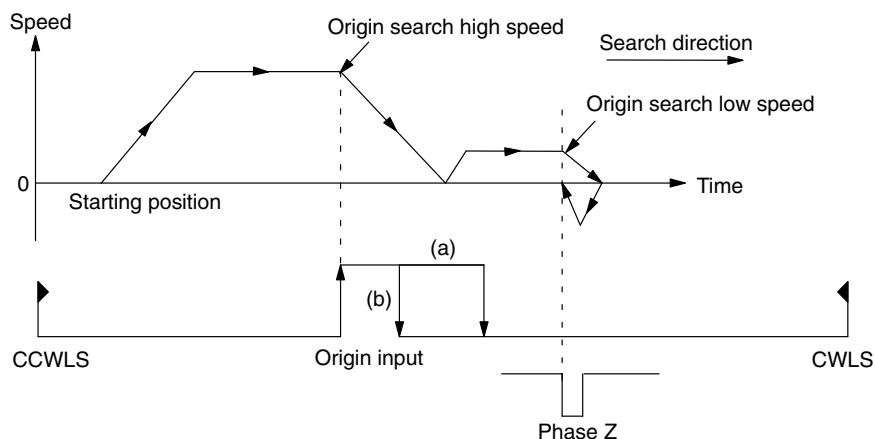

**Search Starting between CW Limit Input and Origin Input**

- 1, 2, 3... 1. Movement starts in the search direction at high origin search speed.
2. Movement stops and reverses direction at the CW limit input.
3. Movement stops at the leading edge of the origin input, reverses direction, and continues at low origin search speed.

- The origin is established at the first phase Z pulse after the trailing edge of the origin input.

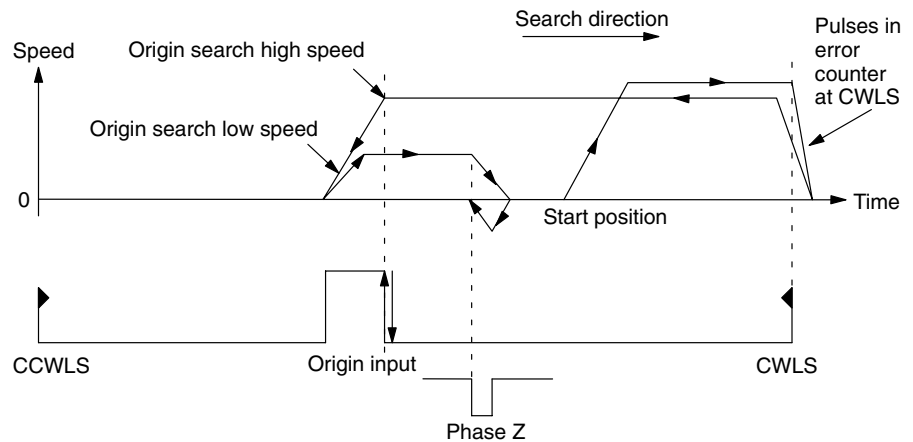

### 7-3 Origin Compensation

The encoder phase Z position may not always designate the mechanical origin as desired. Sometimes the origin may be preferred a few pulses CW or CCW from the phase Z pulse. In order to correct the origin's position, set the origin compensation parameter (addresses 414 for the X axis and 814 for the Y axis) with the amount of compensation desired. Once the parameter is set, the origin is established according to the desired compensation from the phase Z pulse detected during origin search.

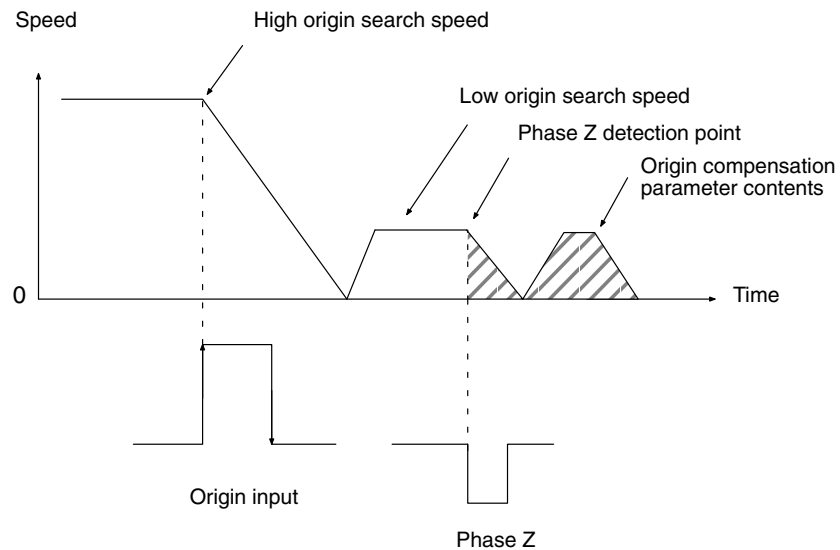

# SECTION 8

## Programming Examples

This section provides example PC programs along with the commands and sample data used to achieve various types of positioning actions.

8-1	Data Word Allocations .....	102
8-2	Data Transmission Program .....	105
8-3	Basic Program Examples .....	108
	8-3-1 Positioning to a Single Point (X Axis) .....	108
	8-3-2 Positioning to a Single Point (Y Axis) .....	108
	8-3-3 Straight-Line Interpolation to a Single Point (X/Y Axis) .....	110
	8-3-4 Circular Arc Interpolation (Center Designated) .....	111
	8-3-5 Circular Arc Interpolation (Intermediate Point Designated) .....	112
	8-3-6 Continuous Positioning .....	113
8-4	Application Program Examples .....	115
	8-4-1 Digital Switch Positioning .....	115
	8-4-2 Circular Arc Positioning .....	118
	8-4-3 Multiple Positioning .....	122

## 8-1 Data Word Allocations

The lowercase letters j, k, l, m, and n designate the IR and DM area words for the programming examples in this section. The Position Control Unit is mounted on word n for output and word n+1 for input. The value n depends on the mounting position of the Position Control Unit. The following DM area entries for commands and positioning actions should be cross-referenced to programming examples that follow. Refer to the formats for commands (*6-1 Command Format*) and positioning actions (*3-4 Setting Positioning Actions*).

### Command DM Area (m-m+32)

DM No. \ Bit	b <sub>15</sub> -b <sub>12</sub>	b <sub>11</sub> -b <sub>8</sub>	b <sub>7</sub> -b <sub>4</sub>	b <sub>3</sub> -b <sub>0</sub>	Remark
m	0	1	0	1	Positioning to point A ( <i>Section 8-3-1</i> ).
m+1	1	0	0	0	
m+2					
m+3	0	3	0	1	Straight-line interpolation to origin ( <i>Section 8-3-3</i> ).
m+4	1	0	2	0	
m+5					
m+6	0	3	0	1	Circular arc interpolation with center designation ( <i>Section 8-3-4</i> ).
m+7	1	0	3	0	
m+8					
m+9					
m+10	0	3	0	1	Circular arc interpolation with intermediate point designation ( <i>Section 8-3-5</i> ).
m+11	1	0	5	0	
m+12					
m+13					
m+14					
m+15					
m+16	0	2	0	1	Positioning to point C via point B ( <i>Section 8-3-2</i> ).
m+17	5	0	0	0	
m+18					
m+19					
m+20	0	3	0	3	Straight-line interpolation
m+21	1	0	2	0	Circular arc center
m+22	1	0	3	0	Circular arc intermediate point
m+23	1	0	4	0	Series of interpolation commands
m+24					Continuous interpolated positioning ( <i>Section 8-3-6</i> )
m+25					
m+26					
m+27					
m+28					
m+29					
m+30					

DM No. \ Bit	b <sub>15</sub> -b <sub>12</sub>	b <sub>11</sub> -b <sub>8</sub>	b <sub>7</sub> -b <sub>4</sub>	b <sub>3</sub> -b <sub>0</sub>	Remark
m+31					
m+32					

**Positioning Actions in DM Area**

DM No. \ Bit	b <sub>15</sub> -b <sub>12</sub>	b <sub>11</sub> -b <sub>8</sub>	b <sub>7</sub> -b <sub>4</sub>	b <sub>3</sub> -b <sub>0</sub>	Remarks
k	1	0	0	4	X-axis address 100, point A
k+1	0	0	0	1	
k+2	0	0	0	0	
k+3	0	2	1	0	
k+4	1	5	0	4	X-axis address 102, origin (straight-line interpolation end point )
k+5	1	0	2	4	
k+6	0	0	0	0	
k+7	0	0	0	0	
k+8	0	1	3	0	
k+9	1	5	4	4	
k+10	1	0	3	4	
k+11	0	0	0	1	
k+12	0	0	0	0	
k+13	0	2	0	0	
k+14	0	0	C	6	
k+15	1	0	4	4	X-axis address 104, (interpolation end point)
k+16	0	0	0	0	
k+17	0	0	0	0	
k+18	0	2	3	0	
k+19	1	5	4	4	
k+20	1	0	5	4	X-axis address 105, point D (interpolation end point)
k+21	0	0	0	0	
k+22	0	0	0	0	
k+23	0	2	0	0	
k+24	0	0	8	5	
k+25	1	0	6	4	X-axis address 106, point C
k+26	0	0	0	1	
k+27	0	0	0	0	
k+28	0	2	0	0	
k+29	1	5	4	5	
k+30	1	0	7	4	X-axis address 107, point A
k+31	0	0	0	1	
k+32	0	0	0	0	

DM No. \ Bit	b <sub>15</sub> -b <sub>12</sub>	b <sub>11</sub> -b <sub>8</sub>	b <sub>7</sub> -b <sub>4</sub>	b <sub>3</sub> -b <sub>0</sub>	Remarks
k+33	0	0	0	0	X-axis address 108, origin
k+34	0	0	8	4	
k+35	1	0	8	4	
k+36	0	0	0	0	
k+37	0	2	3	0	
k+38	0	2	3	0	
k+39	1	5	4	4	

DM No. \ Bit	b <sub>15</sub> -b <sub>12</sub>	b <sub>11</sub> -b <sub>8</sub>	b <sub>7</sub> -b <sub>4</sub>	b <sub>3</sub> -b <sub>0</sub>	Remark
k+50	5	0	0	9	Y-axis address 500, point B
k+51	0	0	0	9	
k+52	0	0	0	0	
k+53	5	0	0	0	
k+54	0	3	2	0	
k+55	1	0	0	5	Y-axis address 501, point C
k+56	0	0	0	1	
k+57	0	0	0	0	
k+58	0	1	2	1	
k+59	1	1	0	4	Y-axis address 502, origin (straight-line interpolation end point)
k+60	0	0	0	0	
k+61	0	0	0	0	
k+62	0	2	3	0	
k+63	1	1	4	4	
k+64	0	0	0	1	Y-axis address 503,m point C (circular arc center)
k+65	0	0	0	0	
k+66	0	2	0	0	
k+67	0	0	C	6	
k+68	0	0	0	1	Y-axis address 504, origin (interpolation end point)
k+69	0	0	0	0	
k+70	0	2	3	0	
k+71	1	5	4	4	
k+72	0	0	0	1	Y-axis address 505, point D (circular arc intermediate point)
k+73	0	0	0	0	
k+74	0	2	0	0	
k+75	0	0	8	5	
k+76	0	0	0	1	Y-axis address 506, point C
k+77	0	0	0	0	



DM No. \ Bit	b <sub>15</sub> -b <sub>12</sub>	b <sub>11</sub> -b <sub>8</sub>	b <sub>7</sub> -b <sub>4</sub>	b <sub>3</sub> -b <sub>0</sub>	Remark
k+78	0	2	0	0	Y-axis address 507, point A
k+79	1	5	4	5	
k+80	0	0	0	0	
k+81	0	0	0	0	
k+82	0	2	0	0	
k+83	0	0	8	4	
k+84	0	0	0	0	Y-axis address 508, origin
k+85	0	0	0	0	
k+86	0	2	3	0	
k+87	1	5	4	4	

**AR Area Reference**

Bit \ Wd	15	14	13	12	11	10	09	08	07	06	05	04	03	02	01	00	Subsection introduced
j	∅												∅	∅	∅	∅	8-3-1
j+1	∅	∅										∅	∅	∅	∅	∅	8-3-2
j+2	∅												∅	∅	∅	∅	8-3-3
j+3													∅	∅	∅	∅	8-3-4
j+4													∅	∅	∅	∅	8-3-5
j+5	∅	∅	∅	∅	∅	∅	∅	∅	∅	∅	∅	∅	∅	∅	∅	∅	8-3-6
j+6																	8-2
j+7																	8-2
j+8																	
j+9																	
j+10						∅	∅	∅	∅	∅	∅	∅	∅	∅	∅	∅	8-4-1
j+11				∅	∅	∅	∅	∅	∅	∅	∅	∅	∅	∅	∅	∅	8-4-2

**IR Area Flag Allocations**

Refer to 5-2 Status Word Allocations. The ladder diagrams and flowcharts in this section designate flags with the word number followed by bit number enclosed in parentheses. For example, I+3 (08) would be word 3, bit 08 in the tables of subsection 5-2. Refer to the tables keeping in mind that all words begin with I (I+0 for word 0).

**8-2 Data Transmission Program**

The following describes the program that transfers positioning actions in the programming examples of 8-3 Basic Program Examples. The same programs can be used to transfer parameters as long as data is consecutive in the DM area and as long as parameter addresses are specified. The basic program in 8-3 Basic Program Examples uses parameters and speeds of the initial data in the memory when the Position Control Unit is shipped. For non-sequential transfers, the address field must be appended for every posi-

tioning action. For sequential transfers, the rightmost BCD digit in the address field of the first positioning action can be changed from 4, which states that four additional words follow the address as a positioning action, to 9. In this case you can set the total number of addresses involved in sequential transfer in the word that follows. Consequently, all address-field words except for the first become unnecessary. The maximum number of addresses for sequential transfer is 31.

### DM Area Settings

The positioning actions (which consist of 5 words each) are written to DM words k to k+39 for the X axis and k+50 to k+87 for the Y axis. Review the Positioning Action DM Area table in *8-1 Data Word Allocations*. Each positioning action has fields for the address, position, speed, M code, dwell time, acceleration and deceleration time, and attributes. Refer to *3-4 Setting Positioning Actions* for further details.

### X Axis

Address	Position (pulses)	Speed	M code	Dwell time	Acceleration and Deceleration time	Attribute 1	Attribute 2	Remarks
100	10,000	02	10	1	5	0	4	Point A
101	–	–	–	–	–	–	–	Empty address
102	0	01	30	1	5	4	4	Origin
103	10,000	02	00	0	0	C	6	Point C, arc center
104	10,000	02	30	1	5	4	4	Interpolation end point
105	0	02	00	0	0	8	5	Point D, arc intermediate
106	10,000	02	00	1	5	4	5	Point C
107	10,000	02	00	0	0	8	4	Point A
108	0	02	30	1	5	4	4	Origin

### Y Axis

Address	Position (pulses)	Speed	M code	Dwell time	Acceleration and Deceleration time	Attribute 1	Attribute 2	Remarks
500	5,000	03	20	1	0	0	5	Point B
501	10,000	01	21	1	1	0	4	Point C
502	0	02	30	1	1	4	4	Origin (interpolation end point)
503	10,000	02	00	0	0	C	6	Point C, arc center
504	10,000	02	30	1	5	4	4	Interpolation end point
505	10,000	02	00	0	0	8	5	Point D, arc intermediate
506	10,000	02	00	1	5	4	5	Point C
507	0	02	00	0	0	8	4	Point A
508	0	02	30	1	5	4	4	Origin

**Transfer Program (1)**

Transfers the 8 positioning actions for the X axis. Because address 101 is empty and has no data, the group of 8 addresses is considered non-sequential.

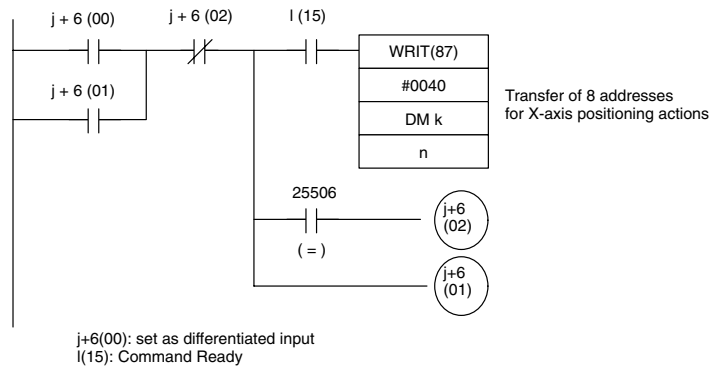

**Transfer Program (2)**

Transfers the 9 positioning actions of the Y axis. Without any empty addresses, the group of 9 positioning actions is considered sequential.

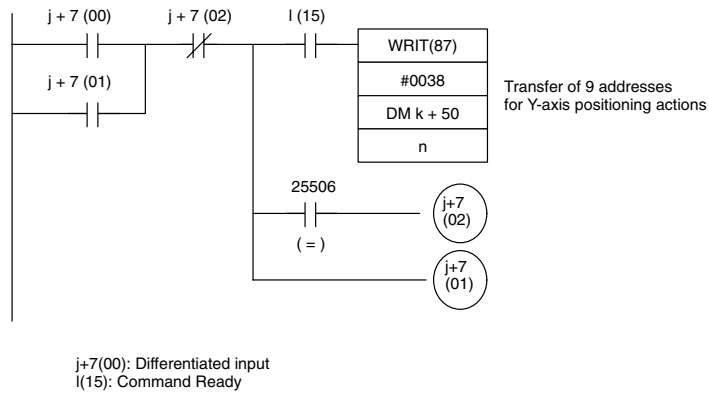

### 8-3 Basic Program Examples

#### 8-3-1 Positioning to a Single Point (X Axis)

The following program positions to point A [10,000, 0 (pulses)] from the origin [0,0 (pulses)] at 2 kpps. At point A, bit J(15) turns ON to indicate completed positioning.

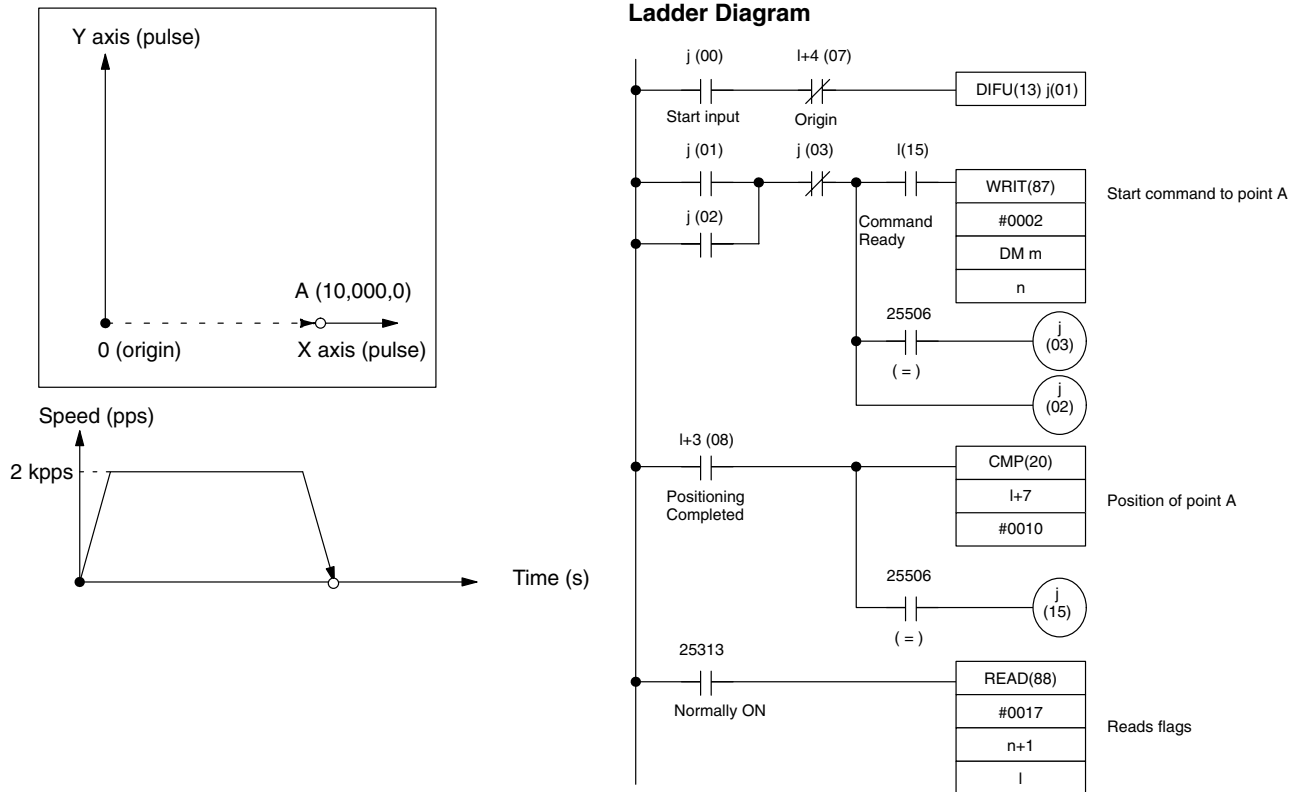

#### 8-3-2 Positioning to a Single Point (Y Axis)

The following program positions to the origin [0, 0 (pulses)] from point C [10,000, 10,000 (pulses)] at 1 kpps. At the origin, bit j+2 (15) turns ON to indicate completed positioning. The speed registered in the X-axis speed field is used.

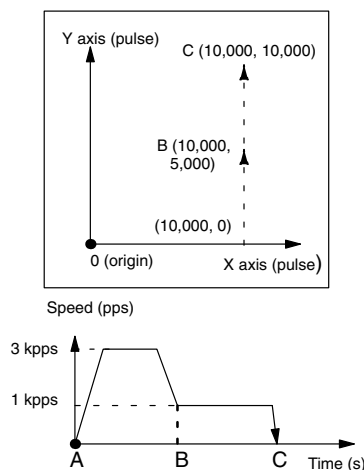

Ladder Diagram

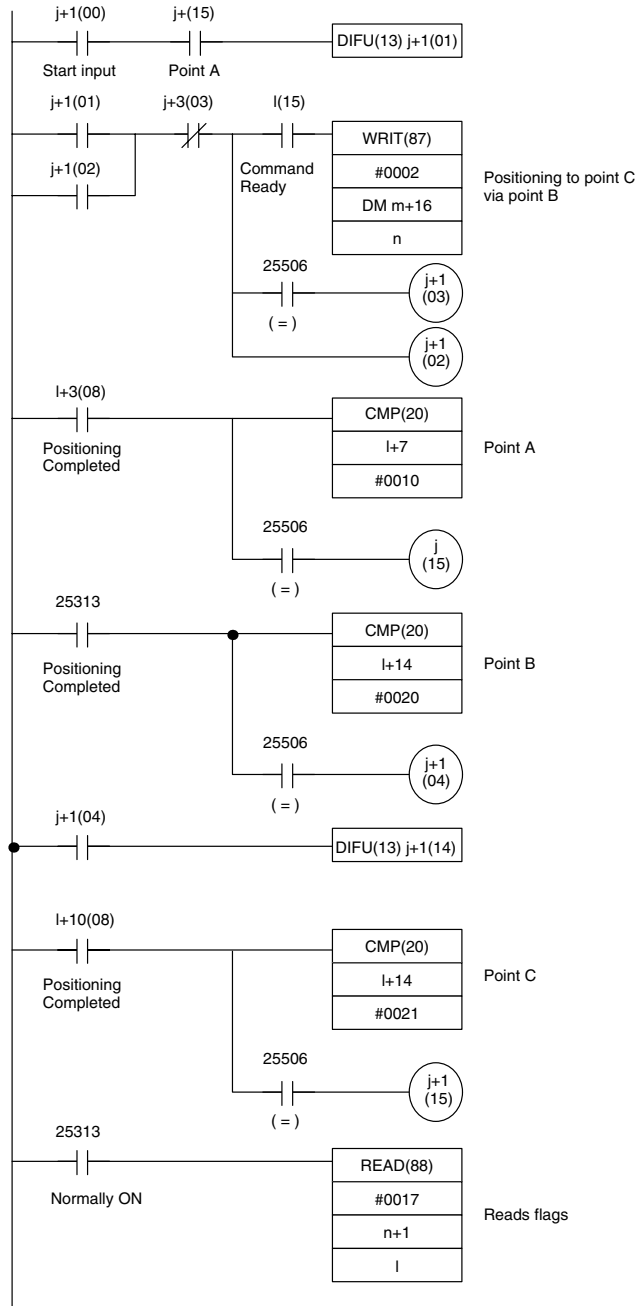

### 8-3-3 Straight-Line Interpolation to a Single Point (X/Y Axis)

The following program positions to point C [10,000, 10,000 (pulses)] from point A [10,000,0 (pulses)] via point B [10,000, 5,000 (pulses)]. Positioning starts at 3 kpps, but drops to 1 kpps at point B. At point B, bit j+1 (14) turns ON for one scan, and bit j(15) turns ON at point C to indicate completed positioning.

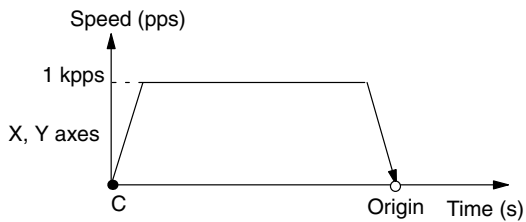
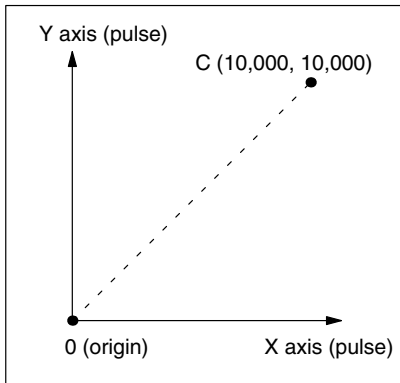

Ladder Diagram

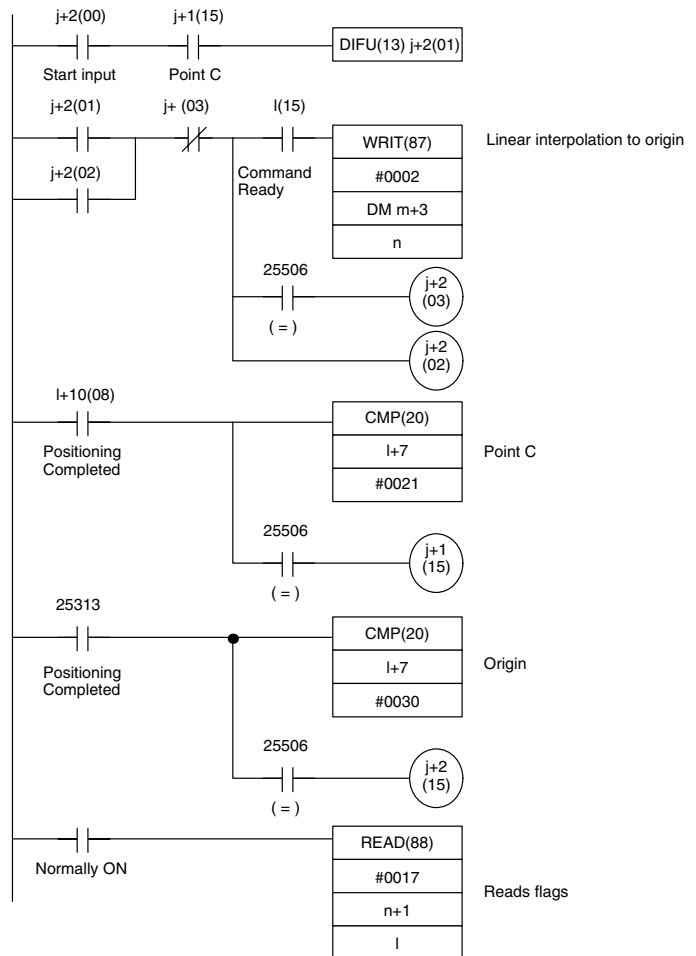

### 8-3-4 Circular Arc Interpolation (Center Designated)

The following program positions a circle counter-clockwise with point C [10,000, 10,000 (pulses)] as the center starting from the origin [0,0 (pulses)] at 2 kpps. At the origin, bit j+2 (15) turns ON to indicate completed positioning. For circular arc interpolation with a designated center, the starting point, center, and end point must be correctly assigned to avoid an error. An error occurs when the three points chosen cannot produce a circular arc. Computation in millimeter and inch units can generate rounding errors. Acceleration and deceleration times are not used.

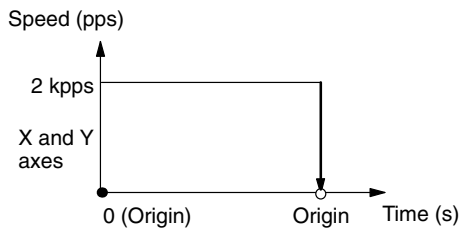
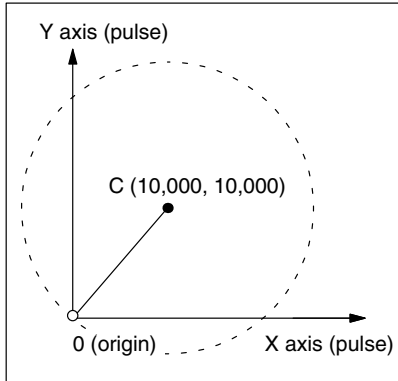

Ladder Diagram

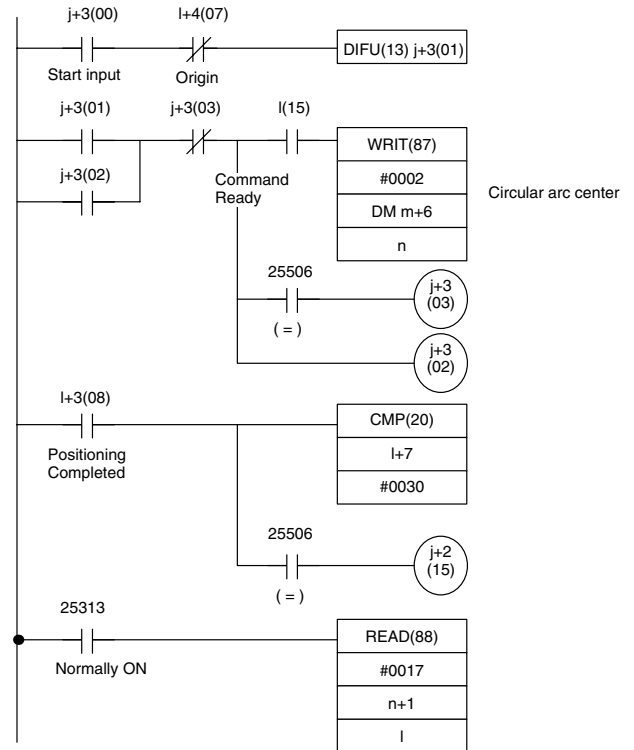

### 8-3-5 Circular Arc Interpolation (Intermediate Point Designated)

The following program positions a circle counter-clockwise with point C [10,000, 10,000 (pulses)] as the intermediate point starting from the origin [0,0 (pulses)] at 2 kpps. With intermediate point D [0, 10,000 (pulses)] interpolation proceeds to point C at 2 kpps. Without stopping, interpolation completes at the origin via intermediate point A [10,000, 0 (pulses)]. At the origin, bit j+2 (15) turns ON to indicate completed positioning. For circular arc interpolation with a designated intermediate point, the entire circumference of a circle cannot be produced because the center cannot be computed. Again, acceleration and deceleration times are not used.

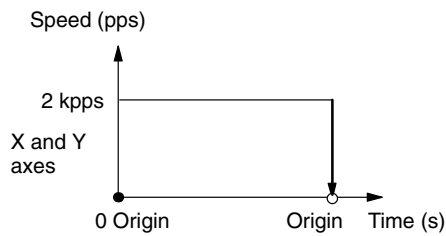
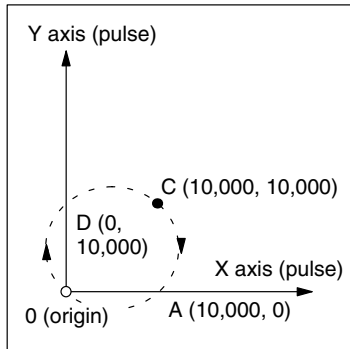

Ladder Diagram

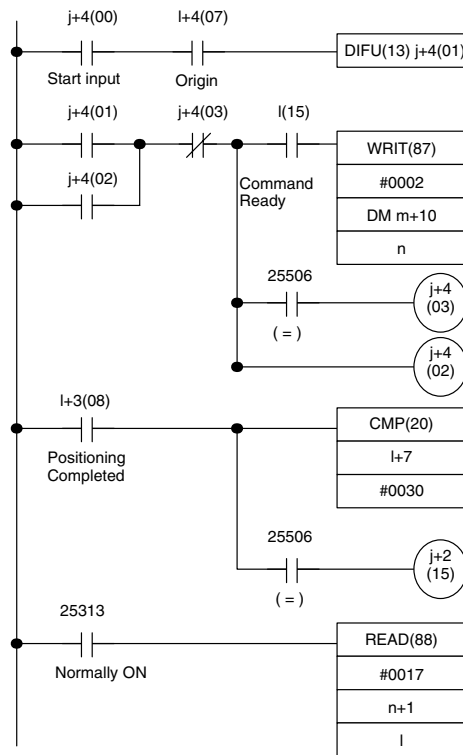



### 8-3-6 Continuous Positioning

This program is a continuous program of all positioning from subsections 8-3-1 through 8-3-5. Positioning follows the order (1)-(5) as shown in the figure. However, at point A, bit j+5 (15) turns ON for one scan; at point B, bit j+5 (14) turns ON for one scan; at point C, bit j+5 (13) turns ON for one scan; and at the origin, bit j+5 (12) turn ON for one scan.

First, the X-axis motor moves independently to point A. At point A the X-axis M code is 10 and triggers (the integrated signal) the Y-axis motor to move via point B to point C. Next, the Y-axis M code (21) triggers the straight-line interpolation to the origin followed by two consecutive circular arc interpolations, one by designating the center and one by designating the intermediate point. The interpolation series of commands transfers as one command block. This is because only one SRT command for the same axis or axes can be allowed in one command block. Since the last three interpolations all involve the same two axes, transferring together is allowed.

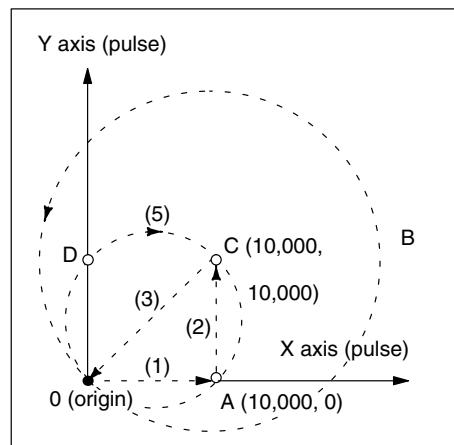

Ladder Diagram

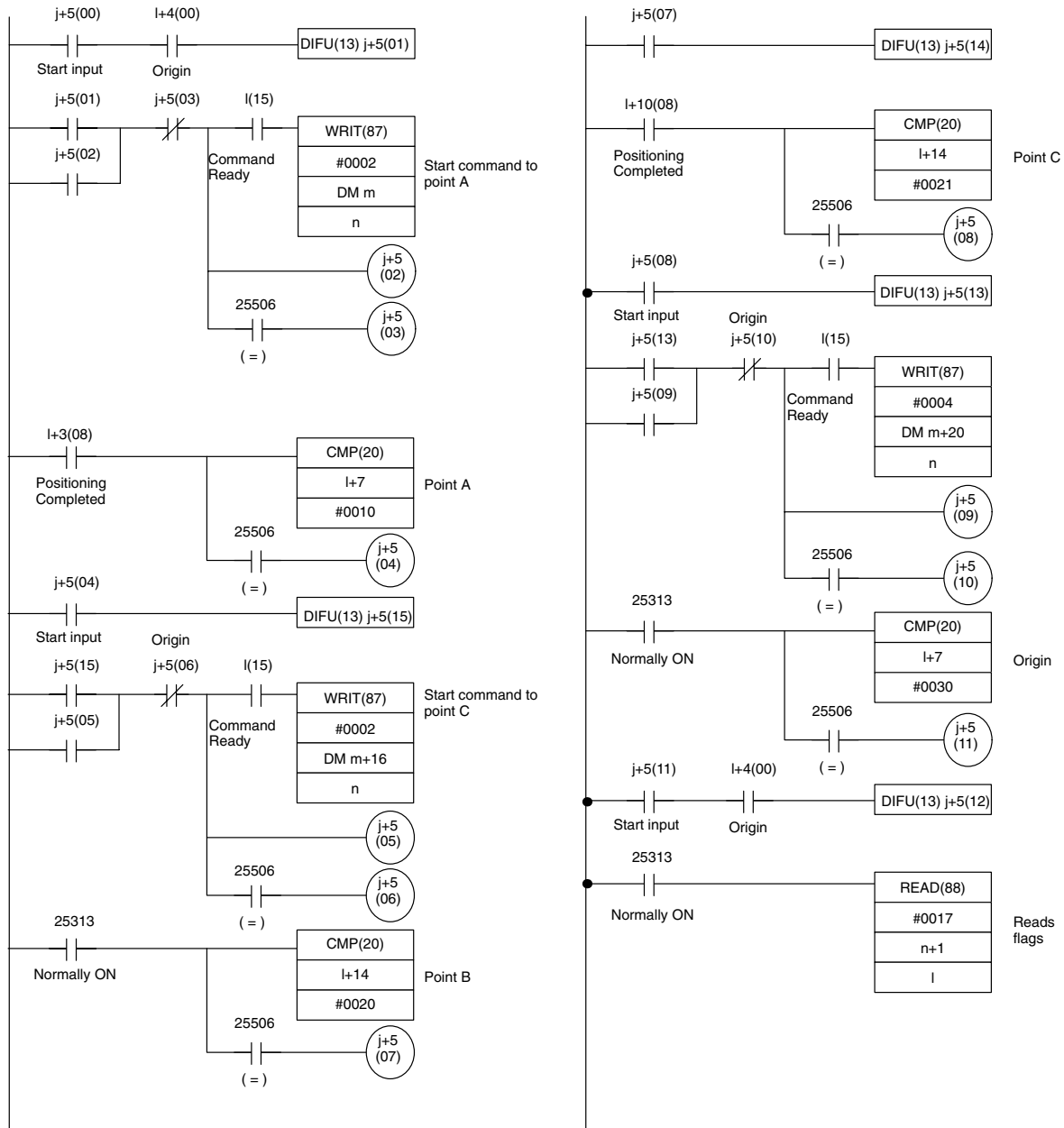

## 8-4 Application Program Examples

### 8-4-1 Digital Switch Positioning

With this program, you set X-axis coordinates, Y-axis coordinates, and speeds with digital switches. Positioning occurs at the set positions when the start switch is turned on. At the positioning point, the motors stop and the M code 55 is output. After stopping for 2 seconds, the axes automatically return to the origin.

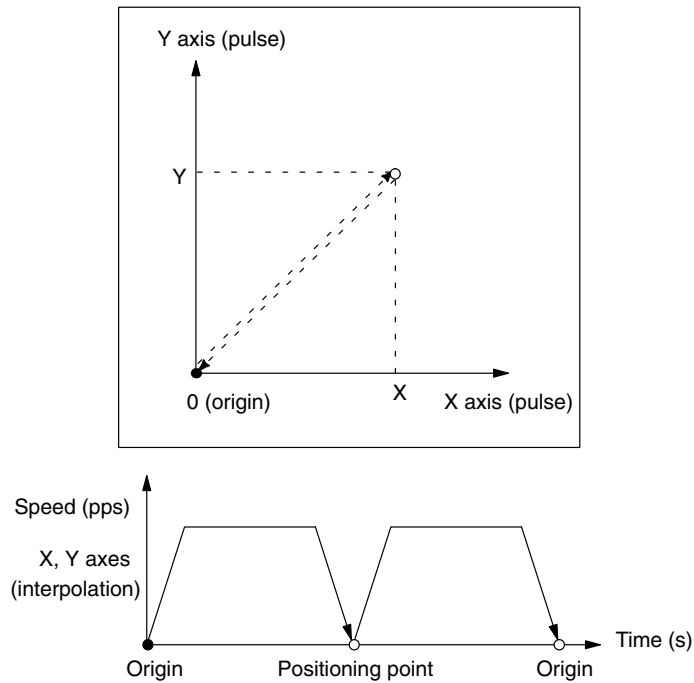

#### AR Area Allocations

n	n+1	n+2	n+3	n+4	n+5	n+6	n+7	n+8	n+9
(OUT)	(IN)	(IN)	(IN)	(IN)	(IN)	(IN)	(IN)	(OUT)	(IN)
PCU		X-axis digital switch		Y-axis digital switch		Speed digital switch		M code output	Start input
		Left-most digits	Right-most digits	Left-most digits	Right-most digits	Left-most digits	Right-most digits		

#### Data Written to DM Area

Word I
Word I+1
:
Word I+16

Word (j+10) is part of the AR area.

## Data Written to DM Area

DM Wd	b <sub>15</sub> -b <sub>12</sub>	b <sub>11</sub> -b <sub>8</sub>	b <sub>7</sub> -b <sub>4</sub>	b <sub>3</sub> -b <sub>0</sub>
p	1	0	0	4
p+1	X-axis position (leftmost digits)			
p+2	X-axis position (rightmost digits)			
p+3	1	0	5	5
p+4	0	1	4	4
p+5	5	0	0	4
p+6	Y-axis position (leftmost digits)			
p+7	Y-axis position (rightmost digits)			
p+8	1	0	5	5
p+9	0	1	4	4
p+10	1	0	1	4
p+11	0	0	0	0
p+12	0	0	0	0
p+13	1	0	0	0
p+14	0	1	4	4
p+15	5	0	1	4
p+16	0	0	0	0
p+17	0	0	0	0
p+18	1	0	0	0
p+19	0	1	4	4
p+20	9	1	0	2
p+21	0	0	Speed (leftmost digits)	
p+22	Speed (rightmost digits)			

## Commands Written to DM Area

DM Wd	b <sub>15</sub> -b <sub>12</sub>	b <sub>11</sub> -b <sub>8</sub>	b <sub>7</sub> -b <sub>4</sub>	b <sub>3</sub> -b <sub>0</sub>
q	0	3	0	1
q+1	1	0	0	0
q+2				
q+3	0	3	0	1
q+4	1	0	1	0
q+5				

Ladder Diagram

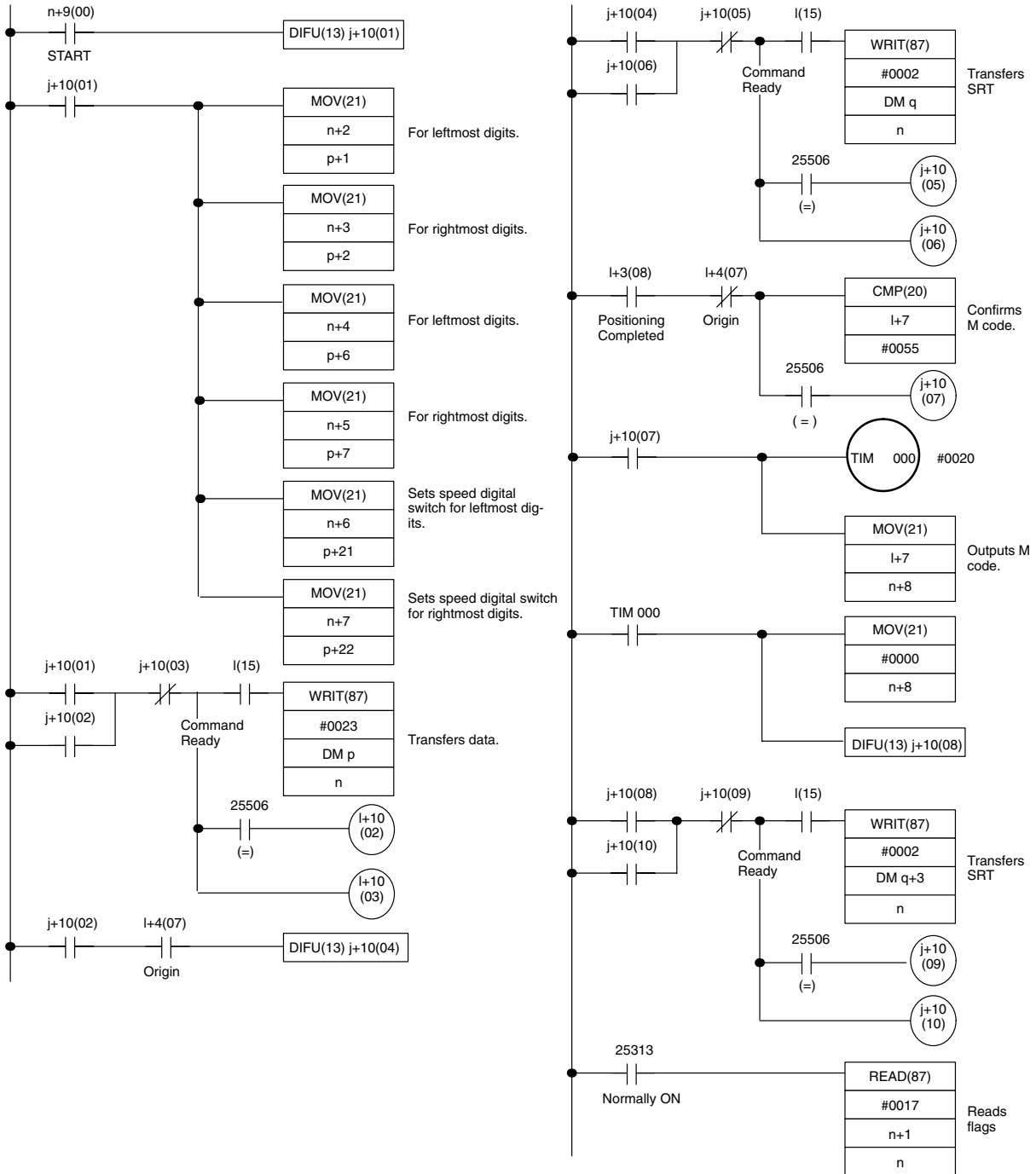

### 8-4-2 Circular Arc Positioning

In this example, the center is already determined, but the digital switches determine the arc radius. The center has been determined at (2,500, 2,500). Set the radius with the digital switches. The axes then construct the prescribed circle starting at the origin and returning to the origin at a speed of 1 pps.

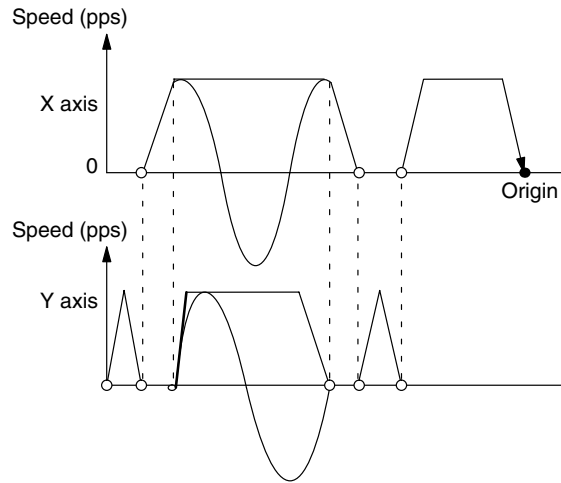
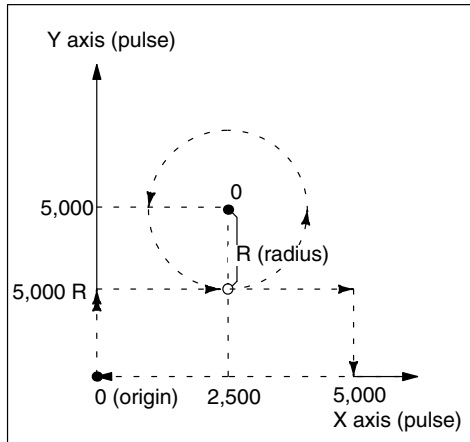

#### IR Area Allocations

n	n+1	n+2	n+5	n+3	n+4	
(OUT)	(IN)	(IN)	(IN)	(IN)	(OUT)	(IN)
PCU		Digital switch	Start input	M code output	Error output	

#### AR Area Allocations

Word l
Word l+1
:
Word l+16

#### DM Area Command Allocations

DM Wd	b <sub>15</sub> -b <sub>12</sub>	b <sub>11</sub> -b <sub>8</sub>	b <sub>7</sub> -b <sub>4</sub>	b <sub>3</sub> -b <sub>0</sub>
s	0	3	0	4
s+1	1	0	0	0
s+2	1	0	1	0
s+3	1	0	5	0
s+4	1	0	6	0

DM Area Data Allocations

DM Wd	b <sub>15</sub> -b <sub>12</sub>	b <sub>11</sub> -b <sub>8</sub>	b <sub>7</sub> -b <sub>4</sub>	b <sub>3</sub> -b <sub>0</sub>
r	1	0	0	4
r+1	0	0	0	0
r+2	0	0	0	0
r+3	0	1	7	7
r+4	0	5	4	4
r+5	1	0	1	4
r+6	0	0	0	0
r+7	2	5	0	0
r+8	0	1	7	7
r+9	0	5	4	5
r+10	1	0	2	4
r+11	0	0	0	0
r+12	2	5	0	0
r+13	0	1	7	7
r+14	0	5	C	7
r+15	1	0	3	4
r+16	0	0	0	0
r+17	2	5	0	0
r+18	0	1	7	7
r+19	0	5	4	5
r+20	1	0	4	4
r+21	0	0	0	0
r+22	5	0	0	0
r+23	0	1	0	0
r+24	0	5	4	4
r+25	1	0	5	4
r+26	0	0	0	0
r+27	5	0	0	0
r+28	0	1	0	0
r+29	0	5	4	4
r+30	1	0	6	4
r+31	0	0	0	0
r+32	0	0	0	0
r+33	0	1	0	0
r+34	0	5	4	4
r+35				
r+36				
r+37				
r+38				
r+39				

Circular arc center

Circular arc end

DM Wd	b <sub>15</sub> -b <sub>12</sub>	b <sub>11</sub> -b <sub>8</sub>	b <sub>7</sub> -b <sub>4</sub>	b <sub>3</sub> -b <sub>0</sub>	
r+40	5	0	0	4	
r+41	0	0	0	0	
r+42					5000 R
r+43	0	1	7	7	
r+44	0	5	4	4	
r+45	5	0	1	4	
r+46	0	0	0	0	
r+47					5000 R
r+48	0	1	7	7	
r+49	0	5	4	5	
r+50	5	0	2	4	
r+51	0	0	0	0	
r+52	5	0	0	0	
r+53	0	1	7	7	
r+54	0	5	C	7	
r+55	5	0	3	4	
r+56	0	0	0	0	
r+57					5000 R
r+58	0	1	7	7	
r+59	0	5	4	5	
r+60	5	0	4	4	
r+61	0	0	0	0	
r+62					5000 R
r+63	0	1	0	0	
r+64	0	5	4	4	
r+65	5	0	5	4	
r+66	0	0	0	0	
r+67	0	0	0	0	
r+68	0	1	0	0	
r+69	0	5	4	4	
r+70	5	0	6	4	
r+71	0	0	0	0	
r+72	0	0	0	0	
r+73	0	1	0	0	
r+74	0	5	4	4	
r+75					
r+76					
r+77					
r+78					
r+79					



Ladder Diagram

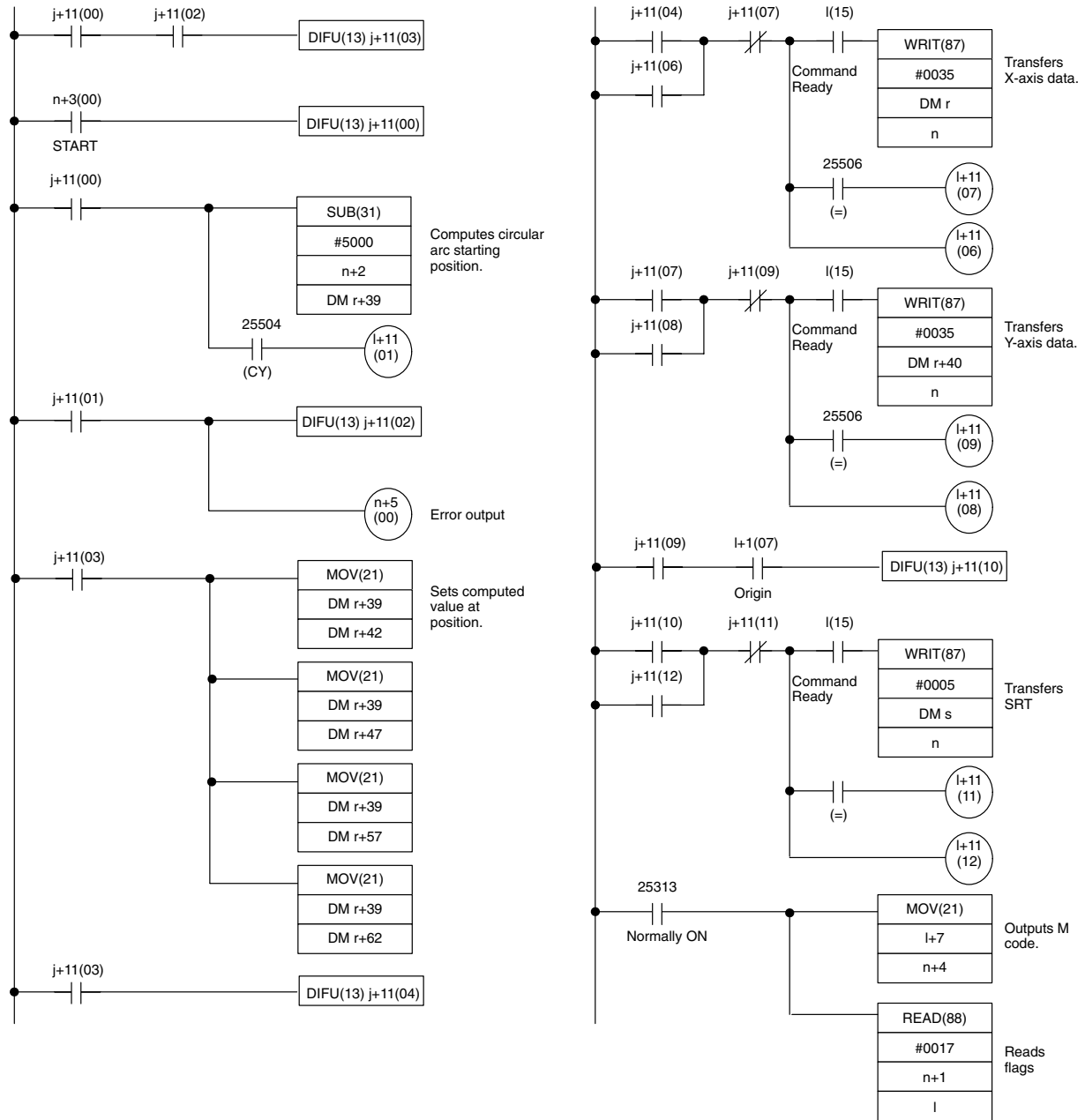

### 8-4-3 Multiple Positioning

This program consecutively executes 25 positioning actions. At each position, an M code is output to indicate arrival. By turning ON the start switch, the motor axes follow the course along the broken lines in the figure below and perform 25 positioning actions. M codes 01-25 are respectively output at each position while the axes stop for 0.5 second. After the 25 positions, the motors return to the origin.

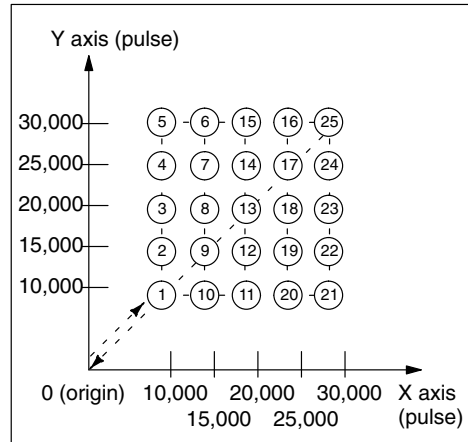

#### IR Area Allocations

n	n+1	n+2	n+3
(OUT)	(IN)	(OUT)	(IN)
PCU		M code output	Start input

#### AR Area Allocations

Word l
Word l+1
:
Word l+16

Word (j+12) is part of the AR area.

## DM Area Allocations

## Data Area

DM Wd	b <sub>15</sub> -b <sub>12</sub>	b <sub>11</sub> -b <sub>8</sub>	b <sub>7</sub> -b <sub>4</sub>	b <sub>3</sub> -b <sub>0</sub>
t	1	0	0	4
t+1	0	0	0	1
t+2	0	0	0	0
t+3	0	1	0	1
t+4	0	0	4	4
t+5	1	0	1	4
t+6	0	0	0	1
t+7	5	0	0	0
t+8	0	1	0	6
t+9	0	0	0	4
t+10	1	0	2	4
t+11	0	0	0	2
t+12	0	0	0	0
t+13	0	1	1	1
t+14	0	0	0	4
t+15	1	0	3	4
t+16	0	0	0	2
t+17	5	0	0	0
t+18	0	1	1	6
t+19	0	0	0	4
t+20	1	0	4	4
t+21	0	0	0	3
t+22	0	0	0	0
t+23	0	1	2	1
t+24	0	0	0	4
t+25	5	0	0	4
t+26	0	0	0	1
t+27	0	0	0	0
t+28	0	1	0	0
t+29	0	0	4	4
t+30	5	0	1	4
t+31	0	0	0	1
t+32	5	0	0	0
t+33	0	1	0	2
t+34	0	0	0	4
t+35	5	0	2	4
t+36	0	0	0	2
t+37	0	0	0	0
t+38	0	1	0	3
t+39	0	0	0	4
t+40	5	0	3	4
t+41	0	0	0	2
t+42	5	0	0	0
t+43	0	1	0	4
t+44	0	0	0	4
t+45	5	0	4	4
t+46	0	0	0	3
t+47	0	0	0	0
t+48	0	1	0	5
t+49	0	0	0	4
t+50	5	0	5	4

DM Wd	b <sub>15</sub> -b <sub>12</sub>	b <sub>11</sub> -b <sub>8</sub>	b <sub>7</sub> -b <sub>4</sub>	b <sub>3</sub> -b <sub>0</sub>
t+51	0	0	0	2
t+52	5	0	0	0
t+53	0	1	0	7
t+54	0	0	0	4
t+55	5	0	6	4
t+56	0	0	0	2
t+57	0	0	0	0
t+58	0	1	0	8
t+59	0	0	0	4
t+60	5	0	7	4
t+61	0	0	0	1
t+62	5	0	0	0
t+63	0	1	0	9
t+64	0	0	0	4
t+65	5	0	8	4
t+66	0	0	0	1
t+67	0	0	0	0
t+68	0	1	1	0
t+69	0	0	0	4
t+70	5	0	9	4
t+71	0	0	0	1
t+72	5	0	0	0
t+73	0	1	1	2
t+74	0	0	0	4
t+75	5	1	0	4
t+76	0	0	0	2
t+77	0	0	0	0
t+78	0	1	1	3
t+79	0	0	0	4
t+80	5	1	1	4
t+81	0	0	0	2
t+82	5	0	0	0
t+83	0	1	1	4
t+84	0	0	0	4
t+85	5	1	2	4
t+86	0	0	0	3
t+87	0	0	0	0
t+88	0	1	1	5
t+89	0	0	0	4
t+90	5	1	3	4
t+91	0	0	0	2
t+92	5	0	0	0
t+93	0	1	1	7
t+94	0	0	0	4
t+95	5	1	4	4
t+96	0	0	0	2
t+97	0	0	0	0
t+98	0	1	1	8
t+99	0	0	0	4
t+100	5	1	5	4

DM Wd	$b_{15}-b_{12}$	$b_{11}-b_8$	$b_7-b_4$	$b_3-b_0$
t+101	0	0	0	1
t+102	5	0	0	0
t+103	0	1	1	9
t+104	0	0	0	4
t+105	5	1	6	4
t+106	0	0	0	1
t+107	0	0	0	0
t+108	0	1	2	0
t+109	0	0	0	4
t+110	5	1	7	4
t+111	0	0	0	1
t+112	5	0	0	0
t+113	0	1	2	2
t+114	0	0	0	4
t+115	5	1	8	4
t+116	0	0	0	2
t+117	0	0	0	0
t+118	0	1	2	3
t+119	0	0	0	4
t+120	5	1	9	4
t+121	0	0	0	2
t+122	5	0	0	0
t+123	0	1	2	4
t+124	0	0	0	4
t+125	5	2	0	4
t+126	0	0	0	3
t+127	0	0	0	0
t+128	0	1	2	5
t+129	0	0	0	4
t+130	1	2	5	4
t+131	0	0	0	0
t+132	0	0	0	0
t+133	0	1	2	6
t+134	0	0	4	4
t+135	5	2	5	4
t+136	0	0	0	0
t+137	0	0	0	0
t+138	0	0	0	0
t+139	0	0	4	4

## Command Area

DM Wd	b <sub>15</sub> -b <sub>12</sub>	b <sub>11</sub> -b <sub>8</sub>	b <sub>7</sub> -b <sub>4</sub>	b <sub>3</sub> -b <sub>0</sub>
t+151	0	3	0	1
t+152	1	0	0	0
t+153	0	2	0	1
t+154	5	0	1	0
t+155	0	2	0	1
t+156	5	0	2	0
t+157	0	2	0	1
t+158	5	0	3	0
t+159	0	2	0	1
t+160	5	0	4	0
t+161	0	1	0	1
t+162	1	0	1	0
t+163	0	2	0	1
t+164	5	0	5	0
t+165	0	2	0	1
t+166	5	0	6	0
t+167	0	2	0	1
t+168	5	0	7	0
t+169	0	2	0	1
t+170	5	0	8	0
t+171	0	1	0	1
t+172	1	0	2	0
t+173	0	2	0	1
t+174	5	0	9	0
t+175	0	2	0	1
t+176	5	1	0	0
t+177	0	2	0	1
t+178	5	1	1	0
t+179	0	2	0	1
t+180	5	1	2	0
t+181	0	1	0	1
t+182	1	0	3	0
t+183	0	2	0	1
t+184	5	1	3	0
t+185	0	2	0	1
t+186	5	1	4	0
t+187	0	2	0	1
t+188	5	1	5	0
t+189	0	2	0	1
t+190	5	1	6	0
t+191	0	1	0	1
t+192	1	0	4	0
t+193	0	2	0	1
t+194	5	1	7	0
t+195	0	2	0	1
t+196	5	1	8	0
t+197	0	2	0	1
t+198	5	1	9	0
t+199	0	2	0	1
t+200	5	2	0	0
t+201	0	3	0	1
t+202	1	2	5	0

Ladder Diagram

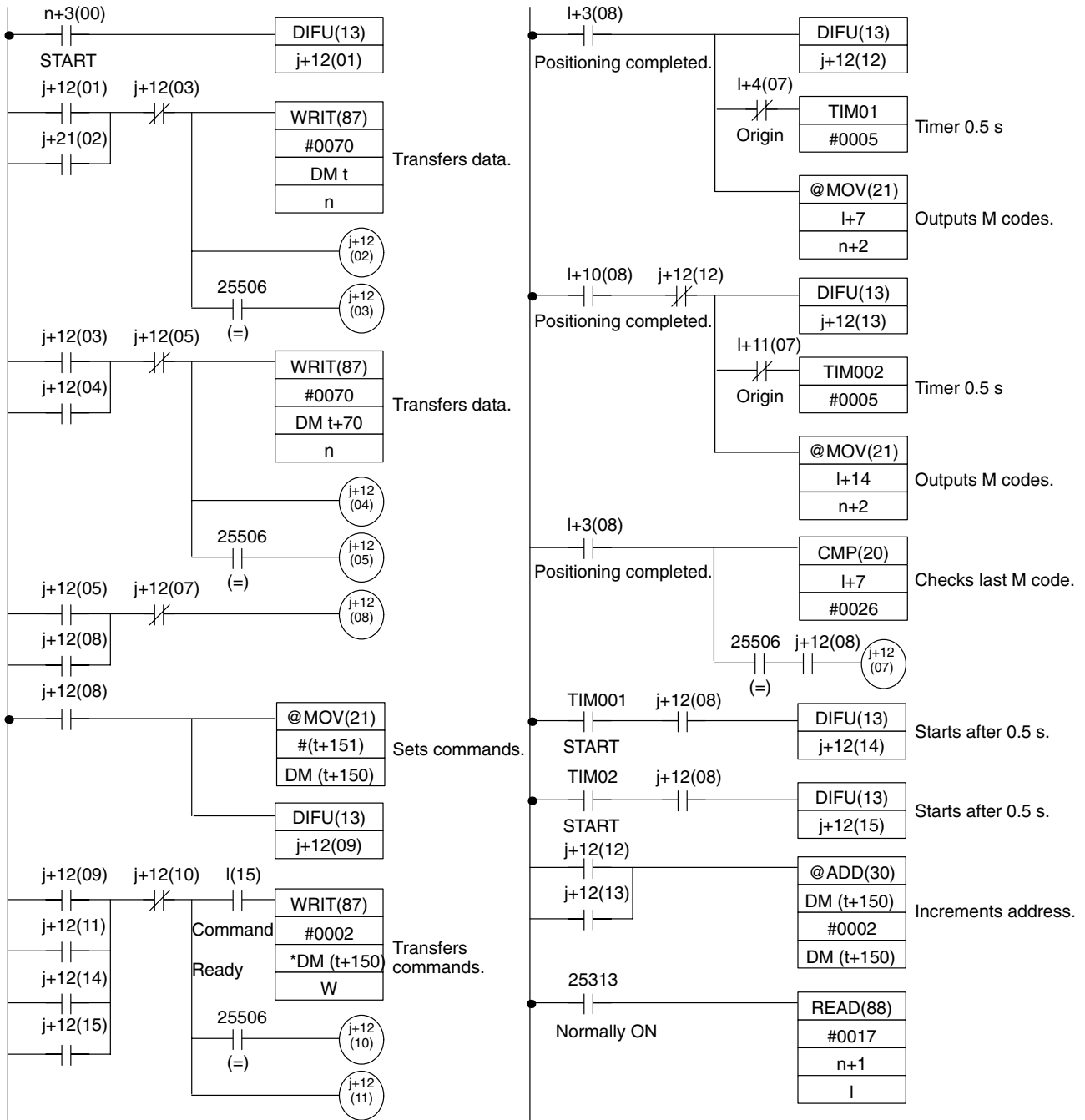

# SECTION 9

## External Display, Switches, and Indicators

9-1	External Display .....	130
9-2	Display Descriptions .....	131
9-3	Switches and Indicators .....	133



## 9-1 External Display

This section provides only an overview of the External Display. Refer to the *Operation Manual*.

### Front Panel

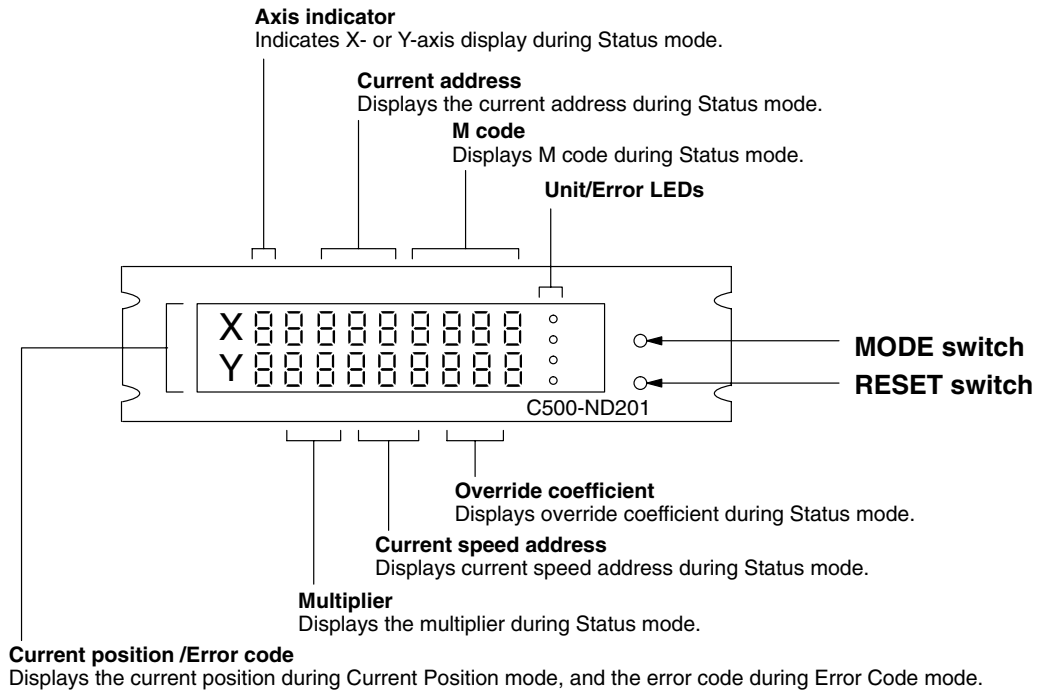

### Moving Between Display Modes

The C500-ND201 External Display has four display modes which can be selected by pressing the MODE and RESET switches.

- 1, 2, 3... 1. When power is turned ON the External Display is in Current Position mode.
2. Each time you press the mode switch, the display mode advances in the order Current Position to X-Axis Status to Y-Axis Status and then back to Current Position. The order circulates in this way no matter what mode you start in.
3. In the two Status modes you can press the RESET switch to return immediately to Current Position mode.
4. The External Display enters the Error Code mode automatically when an error occurs. When the error clears, the display always returns to Current Position mode.

## 9-2 Display Descriptions

### Power ON Operation

Press the RESET switch once after turning on the power. The display shows a series of dashes until the origin has been established (See *Section 7 Establishing the Origin*).

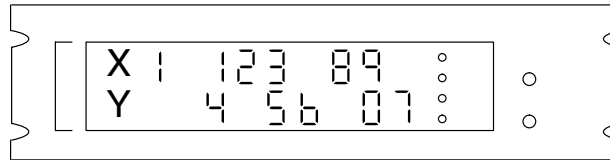

If the display is dark, check the following.

- 1, 2, 3... 1. The 100/200-VAC power supply.
2. The fuses.
3. Crossed wiring between the Position Control Unit and External Display. Check the peripheral connector wiring.
4. The External Display itself may be malfunctioning if all connections and power are correct.

### Current Position Mode

Displays the current position for the X and Y axes. When one axis is unused, the display for that axis will be a series of dashes. There are eight display digits for each axis; this corresponds to the eight BCD digits in the position field for all positioning actions.

The current position is displayed in the selected unit (pulse, mm, inch). The various units have the following ranges.

- 1, 2, 3... 1. For pulse: -99,999,999 to +99,999,999. This is the maximum range of the device in absolute figures.
2. For millimeters: -99,999.999 to +99,999.999. The number of digits below the decimal are fixed at three.
3. For inch: -9,999.9999 to +9,999.9999. The number digits below the decimal are fixed at four.

In other words, the precision remains the full eight digits no matter what units you use. However, you can go over the permitted range in mm and inch units; if this occurs, all digits display "E" as shown below.

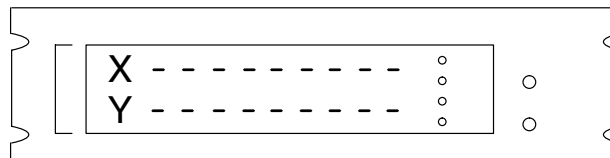

To obtain the number of encoder pulses when you have selected millimeter or inch, multiply the current position by the pulse rate (selected unit/pulse). The pulse rate is described in *3-1 Overview*. In essence, the pulse rate is the actual distance moved by the mechanical system per encoder pulse.

**X-Axis Status and Y-Axis Status Modes**

Display various fields of positioning actions and flags of the AR area. The display is the same for both axes, although information for only one axis can be displayed at a time.

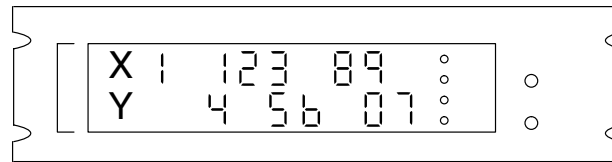

**AXIS**

Designates the axis being displayed: 1: X axis; 2: Y axis.

**EXECUTE ADR.**

Address of current positioning action, 123 in the figure above. While the system is stopped, the address for the next positioning action is displayed.

**M-CODE**

Displays M code currently being output (89 in the figure above). 00 is displayed if no M code is designated.

**MULT. FACTOR**

Displays the current multiplier (4 in the figure).

**SPEED ADR.**

Displays the abbreviated current speed address for the speed designated by the positioning action (56 in the figure).

**OVER-RIDE**

Displays the override coefficient if in effect (0.7 in the figure).

**Error Code Mode**

Displays system and command error codes whenever an error occurs. The display mode automatically turns to Error Code mode in such cases.

**System Errors**

“E0” lights at the axis indicators, followed by an error code display (See *Appendix D* for the error code list). Only one error code is displayed at a time; therefore, the system prioritizes multiple errors. After clearing the indicated error by ERST (error reset), the next error of priority is displayed.

**Command Errors**

“E” lights at the axis indicators. An error code and related OP code are displayed for each axis. The displayed OP code is related to the command error. Only one error code is displayed at a time; therefore, the system prioritizes multiple errors. After clearing the indicated error by ERST (error reset), the next error of priority is displayed.

### 9-3 Switches and Indicators

**Position Control Unit Front Panel**

The front panel of the Position Control Unit is arranged for connections to the Teaching Box (see operation manual), the External Display (see Section 11), the servomotor drivers (see specifications in Appendix C), external input switches, etc. In addition, four LEDs are located on the panel to indicate the current status of the Position Control Unit.

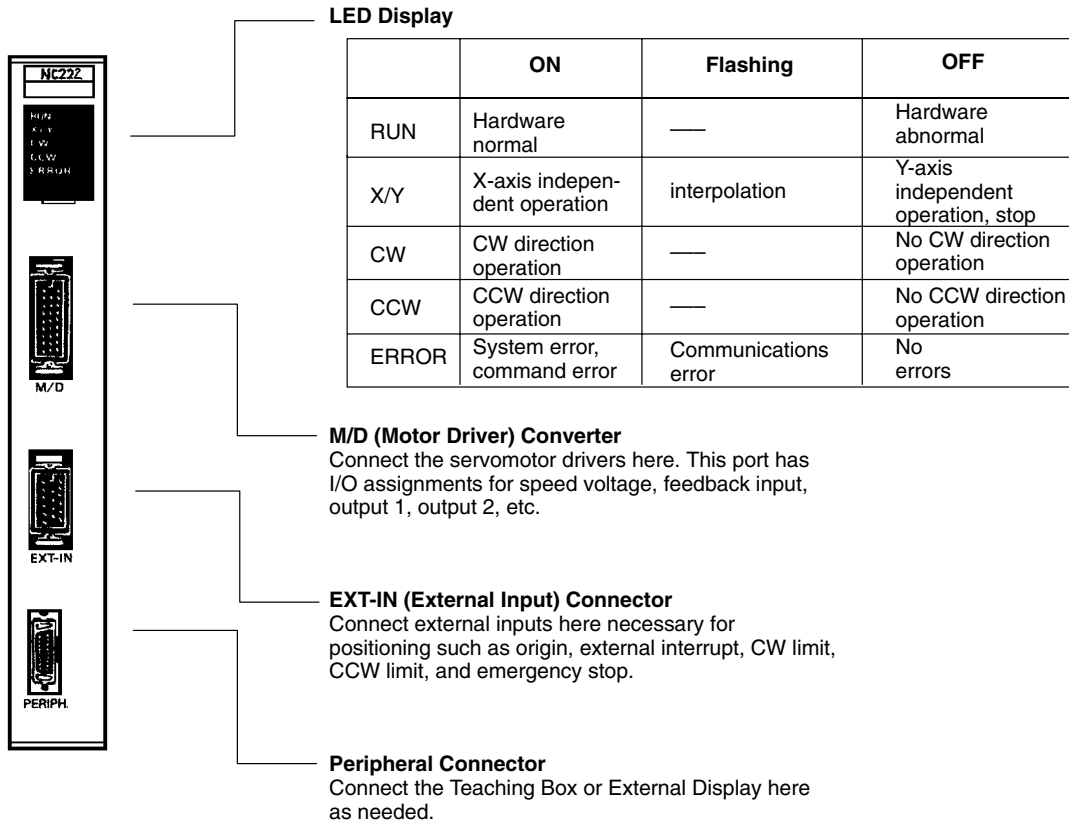

**Definition of CW and CCW**

Clockwise (CW) and counterclockwise (CCW) rotation of the motor shaft are in reference to a viewer facing the shaft on the end of the motor that has no lead cables attached, i.e., the end from which the shaft extends from the motor for connection.

# SECTION 10

## Error Processing

10-1 Procedure .....	136
10-2 Basic Troubleshooting .....	136
10-3 System Errors .....	136
10-4 Command/Data Errors .....	136
10-5 Communications Errors .....	136

## 10-1 Procedure

Error processing is facilitated by the ERROR LED on the Position Control Unit and error code displays on the External Display. The following figure describes the different error processing steps. The three types of errors, system errors, command/data errors, and communications errors, are further classified by their unique error codes (Refer to *Appendix D*). In addition, the ERROR LED on the Position Control Unit lights when there is a system error or command error and flashes when there is a communications error.

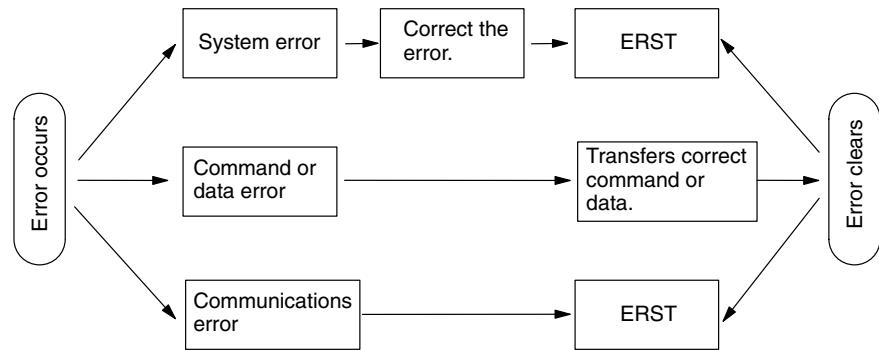

## 10-2 Basic Troubleshooting

If an error occurs, the following general procedure should be used.

- 1, 2, 3... 1. Check the LED status on the Position Control Unit front panel and the flag status.
2. If possible, determine the cause of the error. Check the error code.
3. Correct the cause of the error.
4. Reset the Position Control Unit (ERST).

## 10-3 System Errors

Caused by reasons other than PC commands. System errors have error codes 00-21 (See *Appendix D*). Possible problem areas include Position Control Unit internal hardware, the watchdog timer, the workpiece travelling beyond the CW or CCW limit switch, error counter overflow, and emergency stop. Any of the errors cause the stored origin to be lost. After resetting, begin by establishing the origin.

## 10-4 Command/Data Errors

Caused by PC commands. Command errors are further classified as OP code errors with codes 30-33, operand errors with codes 40-41, and data errors with codes 50-61 (See *Appendix D*). Possible problem areas include incorrect command or data format, commands received at the wrong time (e.g., SRT before ORG), and undefined data.

## 10-5 Communications Errors

Caused by abnormal data communications with Peripheral Devices such as the Teaching Box or External Display. Communication errors have codes 70-72 (See *Appendix D*). Problem areas are parity errors, framing errors, and overrun errors.

# Appendix A

## Position Control Unit Specifications

### General Specifications

Item		Specification
Power supply voltage		5 VDC (for PCU)
		24 VDC (for external power)
Voltage fluctuation tolerance		4.75-5.25 VDC (for PCU)
		21.6-26.4 VDC (for external unit power)
DC current consumption		950 mA or less for 5 VDC
		50 mA or less for 24 VDC
Dielectric resistance		Between all external terminals and frame ground: 500 VAC for 1 minute at 50/60 Hz
Noise resistance		Power (100 VAC) (a) Normal mode: 1.2 kV (b) Common mode: 1.2 kV I/O (24 VDC) (a) Normal mode: 600 V (b) Common mode: 600 V Conditions: Pulse width 1 $\mu$ s, rise time 1 ns.
Vibration resistance	Mechanical durability	10-25 Hz for 2 hrs each in X, Y, and Z directions with 2 -mm double amplitude
	Malfunction durability	16.7 Hz for 10 min each in X, Y, and Z directions with 1-mm double amplitude
Shock resistance		98 m/s <sup>2</sup> : three times each in X, Y, and Z directions.
Operating temperature		0° to 55°
Operating humidity		35% to 85% (no condensation)
Operating atmosphere		No corrosive gases
Storage temperature		-20° to 65° C
Grounding		To less than 100 $\Omega$
Weight		700 grams or less (excluding connectors)
Dimensions		250.0 (H) x 34.5 (W) x 93.0 (D) mm

## Dimensions (Unit: mm)

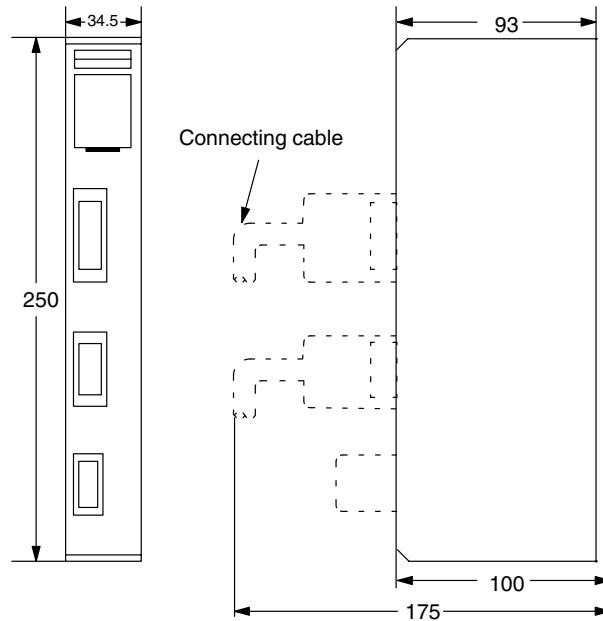

## I/O Electrical Specifications – Inputs

Item	Specification
Input types	Origin, external interrupt, CW limit, CCW limit, Emergency stop
Input voltage	24 VDC $\pm$ 10%
Input current	8 mA
ON voltage	12V min.
OFF voltage	4V max.
ON delay time	2 ms or less
OFF delay time	2 ms or less
Phase inputs	A, B, Z
Phase input voltage	5 VDC $\pm$ 5%
Rated phase input current	10 mA
ON voltage for phase inputs	2.5V min
Response frequency	A, B: 300 kHz max. (50% duty ratio) Z: 10 kHz max.



## I/O Electrical Specifications – Outputs

Item	Specification
Output types	OUT1, OUT2
Maximum open/close capacity	Open collector 40 mA at 24 VDC
Leak current	0.1 mA or less
Residual voltage	1.1 V or less
External power supply voltage	24 VDC $\pm$ 10%
Output type	Speed voltage
Output voltages	-10 to 10 VDC
Output current	10 mA (approx. 1-kW impedance)

## Performance Specifications

Item		Specification
Control method		Semi-closed loop with incremental encoder
No. of control axes		Two
No. of points used by I/O		32 points (2 words)
Peripheral devices		Teaching Box, External Display
Positioning Actions	Settings	(1) From the Teaching Box (2) From the PC with sequence programs
	Position types	Incremental or absolute
	Maximum input	$\pm 99,999,999$ pulses, with conversion to millimeters and inches on the Teaching Box or External Display.
	Data capacity	300 positions per axes
	Interpolation settings	Straight-line interpolation(end point) Circular arc interpolation (arc center and end point, or arc intermediate and end points)
Speeds	Capacity	100 for both axes
	Range	1-300,000 pps (in 1 pps increments)
Parameters	Acceleration/ deceleration method	Automatic trapezoidal acceleration/deceleration curve
	Acceleration/ deceleration times	10 separate acceleration/deceleration times per axis
	Backlash compensation	0-9,999 pulses
	Home shift	To modify positioning actions: 0-999.999 pulses.
	Gain control	1-9.990 $\mu$ V/pulse
	Zone settings	Separate acceleration and deceleration zones
Functions	Origin search	Settings for search directions, high and low search speeds, and origin compensation ( $\pm 999,999$ pulses)
	Jogging	Jogging or inching from PC, Teaching Box
	M functions	M code outputs: 00-99
	Current position	Displayed at the PC, Teaching Box, or External Display
	Deceleration stop	10 settings via acceleration and deceleration times
	Current position preset	Any entry permitted while the system is stopped.
	Data storage	With the EEPROM. All data read in to RAM when power is turned on.
Error checking functions	Error code output	At the PC, Teaching Box, and External Display
	Command trace	Traces commands and external inputs through the past 128 steps. Read the results on the Teaching Box.
	Runaway motor prevention	Prevents a runaway motor through reversed connections for speed voltage and feedback voltage lines.

## Appendix B

### External Display Specifications

Item		Specification
Power supply voltage		100/200 VAC (switch), 50/60 Hz
Voltage fluctuation tolerance		90-110 VAC (for 100 VAC)
		180-220 VAC (for 200 VAC)
Power consumption		100 VA or less
Dielectric impedance		Between all AC external terminals and frame ground: 50 MW or greater (at 500 VDC)
Dielectric resistance		Between all external terminals and frame ground: 1,000 VAC for 1 minute, 50/60 Hz
Noise resistance		Power
		(a) Normal mode: 1.2 kV
		(b) Common mode: 1.2 kV
		Conditions: pulse width 1 $\mu$ s, rise time 1ns.
Vibration resistance	Mechanical durability	10-25 Hz for 2 hr each in X, Y, and Z directions with 2-mm double amplitude
	Malfunction durability	16.7 Hz for 10 min each in X, Y, and Z directions with 1-mm double amplitude
Shock resistance		98 m/s <sup>2</sup> ; three times each in X, Y, and Z directions.
Ambient operating temperature		0 to 55 °C
Ambient operating humidity		35% to 85% (no condensation)
Ambient operating atmosphere		No corrosive gases
Ambient storage temperature		-20° to 65° C
Grounding		To 100 $\Omega$ or less.
Structure		Built into board
Weight		2.5 kg or less (excluding connectors)
Dimensions		70 (H) x 270 (W) x 137 (D) mm

### External Dimensions (Unit: mm)

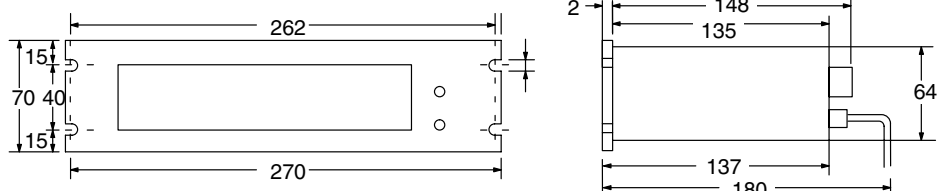

**Mounting Hole Dimensions**

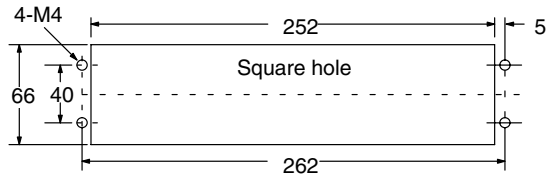

# Appendix C

## Error Code List

### System Errors

Error code	Error type		Time checked	Causes of abnormalities and status	Correction
00*	Hardware error	RAM error	At power ON	RAM abnormality in hardware.	The user cannot correct these errors. Please replace the appropriate part.
		Common RAM error		Common RAM abnormality in hardware.	
		Gate array error		Gate array abnormality in hardware.	
		COMB error		Peripheral LSIs (PIAs, timer ICs) are abnormal.	
01		Bus error	When the bus is accessed (normal).	Bus abnormality in hardware.	
02		EEPROM verification error	When STORE is executed.	EEPROM abnormality in hardware.	
03		Watchdog timer error	Constant	Normal software execution is prevented by noise or other external causes.	
10	X axis	Over-traveling error	Constant	The CW or CCW limit input turned ON when the operation was not an origin search.	Perform a JOG operation to move the workpiece away from the CW or CCW limit switch, and then enter ERST (error reset). This erases the stored origin, so you must re-establish the origin.
11	Y axis				
12	X axis	Emergency stop	Constant	Either 1) the PC sent an EMG; 2) the external emergency stop input turned ON; or 3) an emergency stop was entered at the Teaching Box.	Transfer ERST from the PC, or press the ERST key on the Teaching Box.
13	Y axis				
20	X axis	Error counter overflow	Constant	The error counter count exceeded its maximum value ( $\pm 2^{15}$ bits) when a workpiece got caught on or bumped into a obstruction, or the speed voltage exceeded $\pm 10V$ (speed voltage = error counter value X gain setting). The speed voltage can be exceeded if the motor is not able to accelerate to the designated speed within the required time.	Either remove the obstruction, adjust the speed, acceleration time, or server driver, and then perform ERST, and re-establish the origin
21	Y axis				

\*These errors can be checked via the LED status on the front panel of the Position Control Unit.

## Command Errors

Error Code	Error Type	Time checked	Cause of abnormalities and status	Correction	
30	OP code errors	Undefined error	When commands are transferred.	An undefined OP code was sent as a command.	Correct the OP code and re-transmit the command.
31		Operand count error		Operands differing from the number defined are attached to the commands.	
32		Transmission timing error	When commands are executed.	To an operating axis, a command valid when the axis is stopped was received.	Consider the PC program timing, and correct the command transfer timing.
33		Interpolation transfer error	When interpolation commands are executed.	A command for a single axis was received during interpolation.	Consider the PC program timing, and correct command transfer during interpolation.
40	Operand errors	Undefined error	When commands are transferred.	An undefined operand was received.	Correct the operand and re-transmit the command.
41		Format error		The operand format is incorrect.	

## Data Errors

Error Code	Error Type	Time checked	Cause of abnormalities and status	Correction
50	Data errors	When ISRT is transferred.	Data designated by ISRT is not interpolation data.	Correct the data and re-transmit the data.
51			Among interpolation data, data for one axis is disabled.	
52			The center or intermediate point is the same as the end point; arc cannot be produced.	
53			No interpolation end point data following the center or intermediate point data.	
54		When data is transferred (WRIT (87)).	Data addressed beyond the defined range was transferred.	Correct the data and re-transmit the data.
55			The data length did not fit the defined range.	
56			Data transfer occurred during axis operation.	Data cannot be transferred during operation. Transfer data while the axes are stopped.
57			Data beyond the defined range was transferred.	Correct the data and re-transmit the data.
58			The data format did not fit the defined range.	
59	Stroke limit error	When XSRT, YSRT, or ISRT is transferred.	The position field of the positioning action exceeded the stroke limit (+) or (-) parameter.	Check the position you wish to execute or check the stroke limit parameters.

Error Code	Error Type	Time checked	Cause of abnormalities and status	Correction
60	Speed 0 error	When SRT, ORG, or JOG is transferred.	The speed called in the positioning action was 0.	Check the speeds or speed fields of the positioning action.
61	Set origin incomplete error	When SRT is transferred.	SRT was transferred before the origin was established.	Establish the origin (Section 9).

## Communication Errors

Error Code	Error Type	Time checked	Cause of abnormalities and status	Correction
70	Parity error	Constant	Parity check uncovered an abnormality.	Clear the error with ERST, and follow the steps below. If the error does not clear, there may be a hardware problem which is not user serviceable. (1) Check cable connections.
71	Framing error		Data format broke down during transfer.	
72	Overrun error		Handshake abnormality	(4) Replace the PCU.
80	Transfer word count overflow (data error)	When data is transferred.	The number of words transferred with WRIT (87) exceeded 127.	Change the PC program so the number of words transferred remains within 127.

# Appendix D

## Position Action Data Coding Sheets

DM Wd	15↔00			Function	DM Wd	15↔00			Function	DM Wd	15↔00			Function
	0	0	1	Unit: 0-2		5	0	1	Dwell time #0 (0-9,990)					
	0	0	0											
	0	1	2	Pulse rate: 1.0-0.0001		5	1	1	Dwell time #1					
	0	0												
	0	2	1	Rotation direction: 0, 1		5	2	1	Dwell time #2					
	0	0	0			5	3	1	Dwell time #3					
	0	3	1	Encoder type: 0-1; 1, 2, 4.		5	4	1	Dwell time #4					
	0	0												
	0	4	1	Gain: 1-999		5	5	1	Dwell time #5					
	0					5	6	1	Dwell time #6					
	0	5	1	In-position zone: 1-999		5	6	1	Dwell time #6					
	0													
	0	6	1	Backlash compensation: 0-9,999		5	7	1	Dwell time #7					
	0					5	8	1	Dwell time #8					
	0	7	2	Stroke limit (+): 0-99,999,999										
	0					5	9	1	Dwell time #9					
	0	8	2	Stroke limit (-): 0-99,999,999										
	0					6	0	2	Acceleration and deceleration time #0 (1-499)					
	0	9	2	Zones: 0-9,999 (acceleration): 0-9,999 (deceleration)	0									
	0				0									
	1	0	2	Home shift: ±999,999	0	6	1	2	Acceleration and deceleration time #1					
	0				0									
	1	1	2	Maximum speed: 1-300,000	0	6	2	2	Acceleration and deceleration time #2					
	0				0									
	1	2	2	Maximum jogging speed: 1-300,000	0	6	3	2	Acceleration and deceleration time #3					
	0				0									
	1	3	1	Origin search direction: 0, 1	0	6	4	2	Acceleration and deceleration time #4					
	0	0	0		0									
	1	4	2	Origin compensation: ±999,999	0	6	5	2	Acceleration and deceleration time #5					
	0				0									
	1	5	2	High origin search speed: 1-300,000	0	6	6	2	Acceleration and deceleration time #6					
	0				0									
	1	6	1	Origin search acceleration and deceleration: 0-9	0	6	7	2	Acceleration and deceleration time #7					
	0	0	0		0									
	1	7	2	Low origin search speed: 1-10,000	0	6	8	2	Acceleration and deceleration time #8					
	0	0	0		0									
	1	8	2	Deceleration stop: 1-100,000	0	6	9	2	Acceleration and deceleration time #9					
	0	0	0		0									
					0									



DM Wd	15↔00	Function	DM Wd	15↔00	Function	DM Wd	15↔00	Function
		Positioning action #1			Positioning action #11			Positioning action #21
		Positioning action #2			Positioning action #12			Positioning action #22
		Positioning action #3			Positioning action #13			Positioning action #23
		Positioning action #4			Positioning action #14			Positioning action #24
		Positioning action #5			Positioning action #15			Positioning action #25
		Positioning action #6			Positioning action #16			Positioning action #26
		Positioning action #7			Positioning action #17			Positioning action #27
		Positioning action #8			Positioning action #18			Positioning action #28
		Positioning action #9			Positioning action #19			Positioning action #29
		Positioning action #10			Positioning action #20			Positioning action #30

DM Wd	15↔00			Function	DM Wd	15↔00			Function	DM Wd	15↔00			Function
			2	Speed #0 (1-300,000)				2	Speed #16				2	Speed #32
	0	0				0	0				0	0		
			2	Speed #1				2	Speed #17				2	Speed #33
	0	0				0	0				0	0		
			2	Speed #2				2	Speed #18				2	Speed #34
	0	0				0	0				0	0		
			2	Speed #3				2	Speed #19				2	Speed #35
	0	0				0	0				0	0		
			2	Speed #4				2	Speed #20				2	Speed #36
	0	0				0	0				0	0		
			2	Speed #5				2	Speed #21				2	Speed #37
	0	0				0	0				0	0		
			2	Speed #6				2	Speed #22				2	Speed #38
	0	0				0	0				0	0		
			2	Speed #7				2	Speed #23				2	Speed #39
	0	0				0	0				0	0		
			2	Speed #8				2	Speed #24				2	Speed #40
	0	0				0	0				0	0		
			2	Speed #9				2	Speed #25				2	Speed #41
	0	0				0	0				0	0		
			2	Speed #10				2	Speed #26				2	Speed #42
	0	0				0	0				0	0		
			2	Speed #11				2	Speed #27				2	Speed #43
	0	0				0	0				0	0		
			2	Speed #12				2	Speed #28				2	Speed #44
	0	0				0	0				0	0		
			2	Speed #13				2	Speed #29				2	Speed #45
	0	0				0	0				0	0		
			2	Speed #14				2	Speed #30				2	Speed #46
	0	0				0	0				0	0		
			2	Speed #15				2	Speed #31				2	Speed #47
	0	0				0	0				0	0		

# Glossary

<b>absolute position</b>	A position given in respect to the origin rather than in respect to the present position.
<b>attribute</b>	One of several types of data that define positioning actions. Attributes include settings such as interpolation code, interpolation point, and completion code.
<b>backlash compensation</b>	Compensation for the amount of mechanical play, or “looseness,” present in gears. Such play can create positioning inaccuracy when the direction of positioning changes.
<b>BCD</b>	An acronym for binary-coded decimal. This is used to code decimal numbers in binary.
<b>circular arc center</b>	An interpolation point which can be defined, along with the interpolation end point, to enable circular arc interpolation. Taking these points as known values, the Position Control Unit can position in a circular arc pattern.
<b>circular arc intermediate point</b>	An interpolation point which can be defined, along with the interpolation end point, to enable circular arc interpolation. Taking these points as known values, the Position Control Unit can position in a circular arc pattern.
<b>circular arc interpolation</b>	Dual-axis positioning in a circular pattern from the present position to a point designated as the interpolation end point. In addition to the interpolation end point, it is necessary to designate either a circular arc center or a circular arc intermediate point.
<b>completion code</b>	A positioning action attribute that determines, upon completion of a given positioning action, whether positioning stops or whether the next positioning action is executed immediately, without a break.
<b>continuous (completion)</b>	The completion code that causes the next positioning action to be executed immediately upon completion of the current one.
<b>CW and CCW</b>	Abbreviations for clockwise (CW) and counterclockwise (CCW). CW and CCW are defined for a motor shaft in reference to a viewer facing the shaft on the end of the motor from which the shaft extends from the motor for connection.
<b>CW/CCW limits</b>	Limits on the CW and CCW sides of the origin which can be internally set to restrict rotation of the shaft.
<b>data area</b>	A memory storage area in the PC. Different types of memory blocks, with differing functions, are stored in the various data areas of the PC. These blocks of memory are built up from single units, or bits, which are grouped into 16-bit words. Commands used to control the Position Control Unit are transferred from a data area in the PC.
<b>distributed control</b>	An automation concept in which each portion of an automated system is located near the devices actually being controlled. In other words, control is decentralized and “distributed” over the system. Distributed control is a concept basic to PC systems.
<b>DM area</b>	A PC data area in which general operating parameters, speeds, and positions for positioning actions are stored.
<b>dwel time</b>	A setting that specifies the period of time during which positioning will stop before execution of the next positioning action.
<b>error code</b>	A four-digit code which is output to the PC and the External Display to identify the type of error which has occurred.
<b>error counter</b>	A device used to ensure positioning accuracy when positioning via pulse trains. The error counter receives a target position as a specific number of pulses in a pulse train from the Position Control Unit and outputs analog speed voltages to drive a servomotor accordingly. The specified number of pulses in the error counter is counted down by feedback from an encoder measuring actual motor shaft movement, causing voltage output to stop when the number of pulses equals zero, i.e., when the target position has been reached.
<b>external interrupt</b>	A function whereby positioning may be stopped or speed may be changed, during operation, in response to an external signal.
<b>feedback</b>	The return of a portion of the output of a circuit or device to its input. It is used in servocontrol systems to help bring actual values closer to target values.

<b>flag</b>	A bit that is turned ON and OFF automatically by the system to provide status information.
<b>gain</b>	The increase in signal power produced by an amplifier.
<b>hunting</b>	The tendency, in servosystems, to overcompensate when the system's momentum carries it past the target position.
<b>inching</b>	Manual feeding wherein positioning is executed one pulse at a time.
<b>incremental position</b>	A position given in respect to the present position, rather than in respect to the origin.
<b>initial position</b>	The present position when a start command is executed.
<b>interpolation</b>	The mathematical calculation of missing values between known values. The Position Control Unit uses interpolation when positioning along both axes simultaneously. There are two types of interpolation possible: straight-line and circular arc.
<b>interpolation code</b>	A setting which determines whether or not a positioning action uses interpolation, and, if so, defines the type of interpolation.
<b>interpolation end point</b>	The point which is defined as the final point for interpolated positioning. The three types of interpolation points are: interpolation end point, circular arc intermediate point, and circular arc center.
<b>M code</b>	An abbreviation for machine code. The user can set various M codes for various positions so that each M code will be output when the workpiece passes its respective position.
<b>NC contacts</b>	Normally-closed contacts. A pair of contacts on a relay that open when the relay is energized.
<b>NO contacts</b>	Normally-open contacts. A pair of contacts on a relay that close when the relay is energized.
<b>op code</b>	An abbreviation for operation code. This code is used to designate the DM area address for each command.
<b>open-loop system</b>	A control system in which operations are carried out according to programmed instructions, but in which feedback is not provided for automatic adjustments.
<b>origin</b>	The point which is designated as 0 at any given time.
<b>origin compensation</b>	A parameter used to correct the origin from the position determined according to the origin input signal.
<b>origin proximity signal</b>	A signal input to indicate when the position is near the origin to enable shifting to a lower speed.
<b>origin proximity</b>	The region near the origin. When positioning enters this region, a proximity switch may output a signal for deceleration.
<b>output code</b>	User-defined codes output following completion of a positioning action.
<b>parameters</b>	Data which determines limits and other conditions under which an operation will be carried out.
<b>positioning action</b>	The fundamental unit of positioning. A particular positioning action moves the workpiece along one or both axes in a direction, at a speed, and to a position determined by the data which has been set as part of the positioning action.
<b>present position</b>	The numeric value in pulses defined as being the "location" of the positioning system at any one point in time. The present position position is not absolute, but rather can be redefined as required by positioning operations.
<b>pulses</b>	Discrete signals sent at a certain rate. The Position Control Unit outputs pulses, each of which designates a certain amount of movement. Such pulses are converted to an equivalent control voltage in actual positioning.
<b>pulse rate</b>	The distance moved the motor shaft divided by the number of pulses required for that movement.
<b>pulse train</b>	A series of pulses output together.
<b>semiclosed-loop system</b>	A control system in which a PC controls an external process without human intervention. This system provides feedback (via a tachogenerator and a rotary encoder) so that actual values (of positions, speeds, and so on) are continuously adjusted to bring them more closely in line with target values.
<b>servolock</b>	An operation whereby a rotary encoder is used to maintain the position of a motor while it is stopped. Whenever the motor axis moves, the rotary encoder sends a feedback pulse to an error counter, causing a rotation voltage to be generated in the reverse direction so that the motor rotates back to its original position.

---

## *Glossary*

---

<b>Special I/O Unit</b>	A dedicated Unit, such as a Position Control Unit, High-Speed Counter Unit, or Analog Timer Unit, which is used for a special purpose.
<b>straight-line interpolation</b>	Dual-axis, linear positioning from the present position to a point designated as the interpolation end point.
<b>target position</b>	A parameter for a positioning action that designates what position is to be reached at the completion of the action.
<b>teaching</b>	Writing the present position into memory, via the Teaching Box, as the target position for the designated positioning action.
<b>terminating (completion)</b>	A completion code that causes positioning to stop upon completion of the current positioning action.
<b>trapezoidal acceleration/deceleration</b>	Accelerating and decelerating in a stepwise pattern such that a trapezoidal figure is formed.
<b>zone</b>	A range of positions or values which can be defined so that flags are turned ON whenever the present position is within the range.

# Index

## A

- acceleration and deceleration times, 2, 39
  - addresses and channels for, 48
  - allocations for, 29
  - for positioning actions, 43
  - setting of, 46
- acceleration and deceleration zones, 36
- addresses, current
  - positioning actions, 76–79
  - speeds, 77
- applicable motors, 2

## C

- circular arc interpolation, 44, 45, 93
  - direction, 45
  - positioning example, 90
  - programming example, 111
- command/data errors, 136
- commands
  - codes, 73
  - data processing, 82, 87
  - descriptions, 84–95
  - format and data channels, 82
  - processing, 89
  - READ DATA, 108, 111, 112
  - relationship with flags, 89
  - servo control, 82, 85
  - SET ADDRESS, 115
  - system, 82, 84
- communications errors, 136
- completion code, 44
- connections, position of, 133
- control axes, number of, 2
- control system, configuration of, 6

## D

- data
  - allocations, 29
  - backup, 2
  - capacity and storage, 2
  - communication between PC and PCU, 58
    - Intelligent I/O Read and Write instructions, 59
  - configuration, 2, 27
  - setting sequence, 28
  - transfer
    - command code, 73
    - programming example from Position Control Unit to PC, 111, 112
  - types, 28
  - word allocations, 68–79
- DC relays, protection for, 26
- deceleration stop, 40
- deviation counter capacity, 41
- direction, definition of CW and CCW, 133
- dwelling times, 2
  - allocations for, 29
  - for positioning actions, 42

## E

- emergency stop input, 22
- encoder characteristics, 30
- error codes
  - displays, 136
  - Error Code mode, 132
  - OP codes, 72–79
  - transmission, 2
- error counter, 7, 8, 9, 22, 23
- errors
  - command/data, 135, 136
  - communications, 135, 136
  - OP codes, 72–79
  - processing, 135
  - system, 132, 135, 136
- external inputs, 21, 133
  - interrupt inputs, 22
- external output control, 42
- external outputs, wiring, 22

**F**

flags  
  allocation, 59  
  changes, 77–79  
    during JOG operations, 78  
    during origin search, 78  
    during positioning, 77  
  error code, 71–79  
  IR area, 66  
  relationship with commands, 89  
  status (1), 72–79  
  status (2), 73–79  
  status flag reception, 60  
  status for errors, 136  
  system, 70–79  
  system error, 71–79  
  transitions, 66–79  
  types, 66–79

**G–I**

grounds, 26

I/O connector  
  pin layout, 18, 21–26  
  position of inputs and outputs, 18

indicators  
  axis, 132  
  error displays, 136  
  positions, 133

inductive loads, protection for, 26

inputs, emergency stop, 22

inputs and outputs  
  circuitry, 20  
  position on I/O connector, 18, 21–26

interpolation code, 43

**L–N**

LEDs (See indicators.), 136

M/D Connector, 18–26

NC221 mode, differences with C500-NC221-E, 10

noise, precautions for, 26

**O**

origin  
  compensation, 38, 100  
  search, 38, 98  
  search patterns, 98

origin search  
  acceleration and deceleration, 40  
  addresses for parameters, 98  
  high and low speed, 98  
  high speed, 39  
  low speed, 40

**P**

parameter  
  deceleration-stop, 22  
  multiplier, 32  
  origin search, 98

parameters, 2  
  allocations, 29  
  number per axis in Position Control Unit, 2  
  origin compensation, 100  
  origin search, 98  
  positioning actions, 29  
  rotation direction, 44  
  setting, 28, 29  
  Y-axis, 51  
  zone setting, 36

position control loops, 23

position field sign, 43, 44

positioning, 9  
  interpolated, 90  
  operations, 4  
  pulses required for specific movement, 10

positioning action enabled or disabled, 44

positioning actions, 2, 36, 37  
  absolute or incremental, 44  
  acceleration or deceleration, 45  
  allocations, 29  
  circular arc interpolation, 93  
  current address, 76–79  
  determination, positive or negative, 33  
  enabled or disabled, 46  
  interpolated positioning, 90  
  interpolation, 44  
  position field sign, 38  
  program examples, 92  
  relation to SRT commands, 95  
  words and fields, 42

positioning system, design of, 9

power cables, 26

power supply  
  line noise, 26  
  lines, 26

precautions, general, xi

programming examples  
  continuous positioning, 113  
  data transmission from PC to Position Control Unit, 101  
    ladder diagram, 107  
  data transmission from Position Control Unit to PC, 111, 112  
  reading data, 108  
  setting the current address, 115

pulse multiplier, 30

pulse rate, 28, 30

## R

relays, protection for, 26

rotation direction parameters, 44

## S

semiclosed-loop system, 6

servoclamp, 8

servolock, 8

servomotor drivers, 6, 7, 9, 18, 23, 32, 133

solenoids, protection for, 26

speeds

  application, 49  
  changes, for positioning, 44  
  current address, 77  
  data format, 49  
  for positioning actions, 42  
  maximum, 37  
  numbers and addresses, 49  
  setting, 48

start time, 62

system configuration, 5

system errors, 136

## T

Teaching Box, 2, 28, 48, 133, 136

troubleshooting, 2

troubleshooting, basic procedure for, 136

## W

wiring

  external outputs, 22  
  faulty, diagnostic function, 23  
  precautions, 24, 26



## Revision History

A manual revision code appears as a suffix to the catalog number on the front cover of the manual.

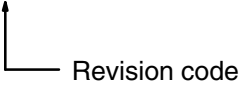
Cat. No. W138-E1-03  

The following table outlines the changes made to the manual during each revision. Page numbers refer to the previous version.

Revision code	Date	Revised content
2	September 1990	<p>Version 2 represents a complete rewrite of the manual in efforts to unify terms and organization of all Position Control Units. In doing this, some terms were changed.</p> <p>There were also changes made as specified below. The page numbers refer to the W138-E1-1 version.</p> <p style="padding-left: 40px;">M/D Connector, Pin Terminal Functions table notation corrected for pins 4, 6, 13, 15, 20, and 22. (p. 11)</p> <p style="padding-left: 40px;">Text correction on p. 15: from "Run-away motors are quite dangerous because they become apparent only after wiring" to "Run-away motors ... become apparent only after switching power on."</p> <p style="padding-left: 40px;">Connection point corrected at lower right of diagram on p.17.</p> <p style="padding-left: 40px;">Corrected connection to IO213-8 of C100H-CPU01-E and removed incorrect ground connection from R88D-V10 TB-C on p. 23.</p> <p style="padding-left: 40px;">Deleted sentence "...All parameters are stored in the EEPROM of the CPU..." (p. 36)</p> <p style="padding-left: 40px;">Default value corrected for Maximum Jogging Speed on p. 43 and for High Origin Search Speed on p. 44.</p> <p style="padding-left: 40px;">Corrected High Origin Search Speed graph and Origin Search Acceleration and Deceleration graph on p. 44.</p> <p style="padding-left: 40px;">Corrected operations for which acceleration and deceleration times are effective. (p. 52)</p> <p style="padding-left: 40px;">Command OP Code table corrected on p. 72</p> <p style="padding-left: 40px;">NOP command description corrected on p. 73.</p> <p style="padding-left: 40px;">Text and positioning diagrams changed on pp. 83 through 85.</p> <p>Ladder diagram symbols were also corrected to agree with standardization given in the PC Operation Manuals.</p>
2A	December 1995	<p>C500-NC221-E changed to C500-NC222-E and references to NC221 mode were added.</p> <p><b>Page 2:</b> <i>External Display for Visual Confirmation</i> deleted from <i>1-1 Features</i>.</p> <p><b>Pages 5, 6:</b> C500-ND201 and Non-transformer Power Supply Units deleted from system configuration.</p> <p><b>Page 10:</b> <i>1-7 Precautions When Using C500-NC222-E in NC221 Mode</i> added.</p> <p><b>Pages 18, 19:</b> Motor Driver connection examples changed.</p> <p><b>Page 27:</b> <i>Gain</i> description changed and added to.</p> <p><b>Page 34:</b> <i>Error Counter Capacity for Emergency Operation Stop and External Output Control</i> added.</p> <p><b>Page 52:</b> <i>Start Time</i> added.</p> <p><b>Pages 58, 70:</b> Data read completion added to the table.</p> <p><b>Page 75:</b> Override coefficient corrected in the table.</p> <p><b>Pages 131, 132:</b> <i>Appendix C Servomotor and Servomotor Driver Specifications</i> deleted.</p> <p><b>Page 134:</b> <i>Data Errors</i> section created.</p>
2B	May 1997	<p>Section of precautions added before section 1 and adjustments made to signal words for precautions.</p>
03	June 2003	<p><b>Page 61:</b> Note added at end of page.</p> <p><b>Pages 137, 141:</b> Unit for shock resistance changed.</p>

**OMRON Corporation**

FA Systems Division H.Q.

66 Matsumoto

Mishima-city, Shizuoka 411-8511

Japan

Tel: (81)55-977-9181/Fax: (81)55-977-9045

**Regional Headquarters**

**OMRON EUROPE B.V.**

Wegalaan 67-69, NL-2132 JD Hoofddorp

The Netherlands

Tel: (31)2356-81-300/Fax: (31)2356-81-388

**OMRON ELECTRONICS LLC**

1 East Commerce Drive, Schaumburg, IL 60173

U.S.A.

Tel: (1)847-843-7900/Fax: (1)847-843-8568

**OMRON ASIA PACIFIC PTE. LTD.**

83 Clemenceau Avenue,

#11-01, UE Square,

Singapore 239920

Tel: (65)6835-3011/Fax: (65)6835-2711

# OMRON

**Authorized Distributor:**

Cat. No. W138-E1-03

SYSMAC C500-NC222-E Two-axis Position Control Unit (NC221 Mode)

OPERATION MANUAL

OMRON

## ***Read and Understand this Manual***

Please read and understand this manual before using the product. Please consult your OMRON representative if you have any questions or comments.

## ***Warranty and Limitations of Liability***

### ***WARRANTY***

OMRON's exclusive warranty is that the products are free from defects in materials and workmanship for a period of one year (or other period if specified) from date of sale by OMRON.

OMRON MAKES NO WARRANTY OR REPRESENTATION, EXPRESS OR IMPLIED, REGARDING NON-INFRINGEMENT, MERCHANTABILITY, OR FITNESS FOR PARTICULAR PURPOSE OF THE PRODUCTS. ANY BUYER OR USER ACKNOWLEDGES THAT THE BUYER OR USER ALONE HAS DETERMINED THAT THE PRODUCTS WILL SUITABLY MEET THE REQUIREMENTS OF THEIR INTENDED USE. OMRON DISCLAIMS ALL OTHER WARRANTIES, EXPRESS OR IMPLIED.

### ***LIMITATIONS OF LIABILITY***

OMRON SHALL NOT BE RESPONSIBLE FOR SPECIAL, INDIRECT, OR CONSEQUENTIAL DAMAGES, LOSS OF PROFITS OR COMMERCIAL LOSS IN ANY WAY CONNECTED WITH THE PRODUCTS, WHETHER SUCH CLAIM IS BASED ON CONTRACT, WARRANTY, NEGLIGENCE, OR STRICT LIABILITY.

In no event shall the responsibility of OMRON for any act exceed the individual price of the product on which liability is asserted.

IN NO EVENT SHALL OMRON BE RESPONSIBLE FOR WARRANTY, REPAIR, OR OTHER CLAIMS REGARDING THE PRODUCTS UNLESS OMRON'S ANALYSIS CONFIRMS THAT THE PRODUCTS WERE PROPERLY HANDLED, STORED, INSTALLED, AND MAINTAINED AND NOT SUBJECT TO CONTAMINATION, ABUSE, MISUSE, OR INAPPROPRIATE MODIFICATION OR REPAIR.

## ***Application Considerations***

### ***SUITABILITY FOR USE***

OMRON shall not be responsible for conformity with any standards, codes, or regulations that apply to the combination of products in the customer's application or use of the products.

At the customer's request, OMRON will provide applicable third party certification documents identifying ratings and limitations of use that apply to the products. This information by itself is not sufficient for a complete determination of the suitability of the products in combination with the end product, machine, system, or other application or use.

The following are some examples of applications for which particular attention must be given. This is not intended to be an exhaustive list of all possible uses of the products, nor is it intended to imply that the uses listed may be suitable for the products:

- Outdoor use, uses involving potential chemical contamination or electrical interference, or conditions or uses not described in this manual.
- Nuclear energy control systems, combustion systems, railroad systems, aviation systems, medical equipment, amusement machines, vehicles, safety equipment, and installations subject to separate industry or government regulations.
- Systems, machines, and equipment that could present a risk to life or property.

Please know and observe all prohibitions of use applicable to the products.

**NEVER USE THE PRODUCTS FOR AN APPLICATION INVOLVING SERIOUS RISK TO LIFE OR PROPERTY WITHOUT ENSURING THAT THE SYSTEM AS A WHOLE HAS BEEN DESIGNED TO ADDRESS THE RISKS, AND THAT THE OMRON PRODUCTS ARE PROPERLY RATED AND INSTALLED FOR THE INTENDED USE WITHIN THE OVERALL EQUIPMENT OR SYSTEM.**

### ***PROGRAMMABLE PRODUCTS***

OMRON shall not be responsible for the user's programming of a programmable product, or any consequence thereof.

## ***Disclaimers***

### ***CHANGE IN SPECIFICATIONS***

Product specifications and accessories may be changed at any time based on improvements and other reasons.

It is our practice to change model numbers when published ratings or features are changed, or when significant construction changes are made. However, some specifications of the products may be changed without any notice. When in doubt, special model numbers may be assigned to fix or establish key specifications for your application on your request. Please consult with your OMRON representative at any time to confirm actual specifications of purchased products.

### ***DIMENSIONS AND WEIGHTS***

Dimensions and weights are nominal and are not to be used for manufacturing purposes, even when tolerances are shown.

### ***PERFORMANCE DATA***

Performance data given in this manual is provided as a guide for the user in determining suitability and does not constitute a warranty. It may represent the result of OMRON's test conditions, and the users must correlate it to actual application requirements. Actual performance is subject to the OMRON Warranty and Limitations of Liability.

### ***ERRORS AND OMISSIONS***

The information in this manual has been carefully checked and is believed to be accurate; however, no responsibility is assumed for clerical, typographical, or proofreading errors, or omissions.